

# Styli & Accessories

Issue 4, August 2019

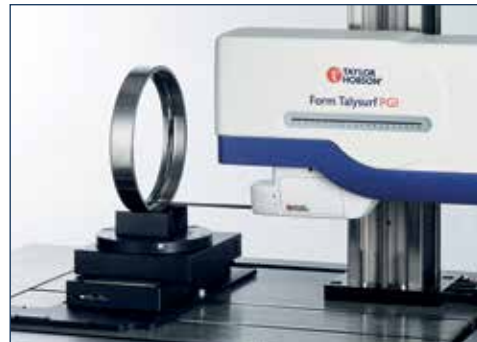

A range of styli and accessories for Taylor Hobson products

# Increase instrument capability

## Fixtures and accessories provide greater flexibility, ease of use and repeatability

Taylor Hobson has focused their efforts on continually improving their technical capability, through investment in machinery and processes, cementing their position as world leaders in metrology solutions.

At the forefront of technical innovation, styli are fundamental to achieving the accuracy and repeatability that our world-leading instruments are renowned for. It is fundamental to measurement accuracy and integrity to only use accessories and styli supplied by Taylor Hobson.

As part of our continuing effort to improve our after sales service, Taylor Hobson now offer an express replacement service for all high volume standard styli, helping to minimise production downtime. Alternatively we offer a fixed cost repair service for all our Form Talysurf® and Talyrond® styli, further helping to reduce running costs.

Work holding accessories are designed to support the measurement of components. They offer accurate and repeatable positioning, essential to achieving optimum system performance. The fixtures and accessories provide greater flexibility, ease of use and reliability.

If our standard styli and accessories do not satisfy your needs, we can customise a solution to exactly match your application. Our team of specialist in house designers have a wealth of experience in providing the most cost effective solutions for any application.

Calibration standards are essential to achieving optimum system performance. Using a calibration hemisphere ensures that the gauge travels through a large proportion of its range, vital for achieving accurate results. Ball calibration standards are used for calibrating the gauge when measurements of form and surface finish are required. Necessary for use with contour or form software, these calibration standards correct for gain, tip and arcuate motion of the stylus.

We are able to offer a traceable calibration certificate using our in house UKAS Laboratory on all our standards, providing reliability, accuracy and confidence in the results. We also provide a re-calibration service which helps maintain this performance throughout the products lifetime.



Talyrond® 585H



Form Talysurf® PGI NOVUS



LUPHOScan 260 HD



Intra Touch



Form Talysurf® i-Series PRO



Ultra Autocollimator



Surtronic® S-100

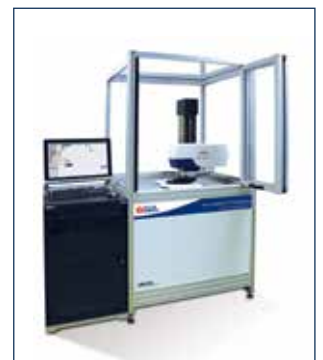

Form Talysurf® PGI Freeform

## Styli - **Form Talysurf®**, **Talyrond®** & **Surtronic®**

Stylus profilometers are often used for two different requirements, surface finish measurement and form (or contour) measurement.

- Recess, chisel, ball, dual tip, forward pointing, nozzle and miniature bore styli
- Completely bespoke styli available through our custom stylus design service



Pages 4-23

## Surface - **Form Talysurf® PGI** & **i-Series**

Measurement systems to improve design, throughput and performance

- Precision systems for surface finish, contour and 3D measurements
- One measurement, multiple results, instant feedback
- Complete trust in your measurements and results



Pages 24-32

## Roundness - **Talyrond®**

A revolutionary concept in automated roundness inspection

- Automated high precision roundness, surface finish, contour
- Five measurements in one
- Harmonic analysis, cylindrical mapping, ball and lead screw analysis

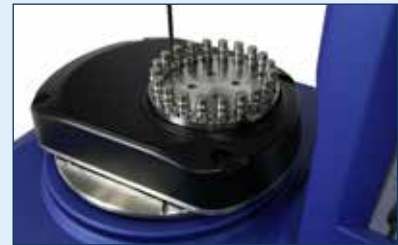

Pages 33-42

## Non-contact - **LUPHOScan**

Ultra-precision non-contact 3D form measurement of aspheric surfaces

- Up to 90° object slopes - ideal for measuring steep, small and large aspheres
- Capable of measuring optics with a diameter of up to 600 mm
- Full 3D form measurement of aspheres, spheres, flats and freeforms

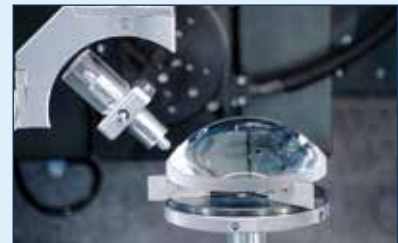

Pages 43-46

## Bench top & handheld - **Surtronic®** range

A range of roundness, surface finish and roughness products

- Bench top roundness - High speed roundness measurement systems
- Handheld - A range of portable and robust surface roughness tester
- Bench top surface - Precision shop floor solutions for surface finish and contour



Pages 47-51

## Alignment & level - **Autocollimator**, **MAT** & **Talyvel®**

Measure angle, straightness, flatness, squareness and parallelism

- Accurate measurement of small angular deviations from a datum angle
- Main applications include checking straightness of machine tool slideways
- Most accurate and stable level in the world with a resolution of 0.1 seconds



Pages 52-61

## Guidelines

**Stylus profilometers are often used for two different requirements, surface finish measurement and form (or contour) measurement. When measuring surface finish it is advisable to use a stylus with the smallest tip radius feasible to fully penetrate all of the surface features.**

The ISO standards dictate the choice of stylus based upon the expected surface finish. ISO 3274 specifies that a conisphere stylus should be used with a tip radius of 2, 5 or 10  $\mu\text{m}$  and a cone angle of either 90 or 60 degrees. It should be noted that some local standards may require a different choice of stylus tip radius. For example, it is common within the automotive industry to use a 5  $\mu\text{m}$  radius tip.

For measuring form or contour, in some circumstances a ball stylus can have certain benefits over a diamond equivalent. The larger radius acts as a filter, reducing some of the effects of surface finish. The larger tip radius also means that a higher tracking force can be used, ensuring that a good contact is maintained with the surface.

## Types of styli

### Ruby

- Doped Monocrystalline aluminium oxide.
- High hardness & Young's modulus.
- Can be polished to a good surface finish.
- Exceptionally smooth surface, good compressive strength and high resistance to mechanical corrosion.

### Silicon Nitride

- Sintered Polycrystalline.
- Can be ground and polished to high diametrical, spherical and surface finish specifications.
- Ideal for soft surfaces such as optically finished aluminium and plastic, as it minimises the attraction of deposits.

### Cone angle selection

Flanking occurs when the slope of the roughness exceeds the angle of the conisphere, the stylus will no longer contact on the spherical tip portion, but on the straight edge (non-measuring surface). This is most clearly evident when measuring a step.

Typically the profile will exhibit a radius followed by an angle that corresponds to the stylus "flank" angle. Our styli are available with a number of different tip cone angles and radii which allow measurement of steep angles. By selecting a suitable ball stylus the possibility of flanking is reduced even further.

### Chisel styli

Used to measure steep angled slopes, radii and threads where it would be impractical to use a diamond or a ball stylus.

### Recess ball styli

Useful for measuring features with deep sags or where using a diamond would increase the risk of flanking or marking of delicate surfaces.

### Dual tip styli

Enables measurement of squareness and perpendicularity with a single stylus, greatly reducing measurement cycle times. They are available with diamond or ruby ball.

### Forward pointing styli

Particularly useful for measuring surface finish on angled slopes in bores, so that the stylus tip remains perpendicular to the measurement surface.

### Miniature bore styli

Used in applications with the smallest clearances, in particular gear profiles, small bores and valve guides.

### Nozzle styli

Predominantly used for measuring small blind holes, such as injector nozzles. They have reduced diameter nose pieces to prevent fouling on internal lands.

## Form Talysurf® Inductive (1 & 2 mm) - Recess styli

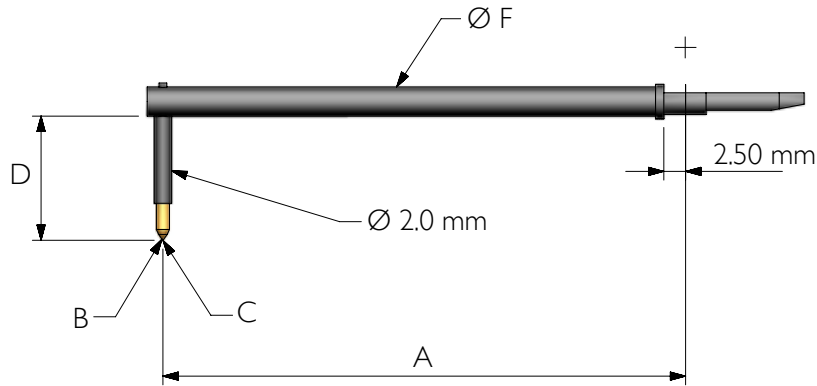

Part no.	Effective length A (mm)	Tip cone angle B (Deg)	Tip radius C ( $\mu\text{m}$ )	Shank clearance D (mm)	Beam diameter F (mm)	Tip
155-P52356	60	60	2	10.70	3.3	Diamond conisphere
112-2009	60	90	2	5.30	3.3	Diamond conisphere
112-2011	60	90	2	11.30	3.3	Diamond conisphere
155-P21215	60	90	5	4.25	3.3	Diamond conisphere
112-2010	120	-	500	11.50	5.0	Ruby ball
155-P56247	120	60	2	12.00	3.3	Diamond conisphere
155-P37279	120	90	2	5.30	3.3	Diamond conisphere
155-P28268	120	90	2	11.30	5.0	Diamond conisphere
155-P54321	120	90	2	20.00	5.0	Diamond conisphere

## Form Talysurf® Inductive (1 & 2 mm) - Forward pointing recess styli

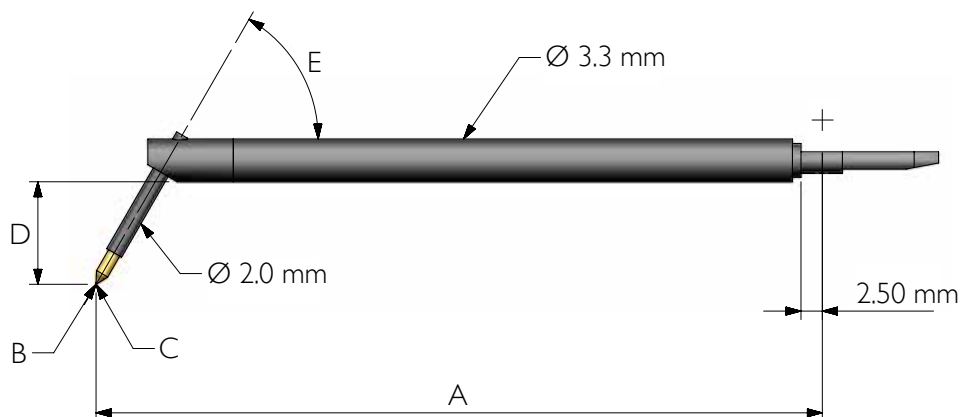

Part no.	Effective length A (mm)	Tip cone angle B (Deg)	Tip radius C ( $\mu\text{m}$ )	Shank clearance D (mm)	Shank angle E (Deg)	Tip
155-P57763	120	60	2	0.80	60	Diamond conisphere
155-P57322	120	60	2	12.00	60	Diamond conisphere

# Instrument Styli

## Form Talysurf® Inductive (1 & 2 mm) - Recess chisel styli

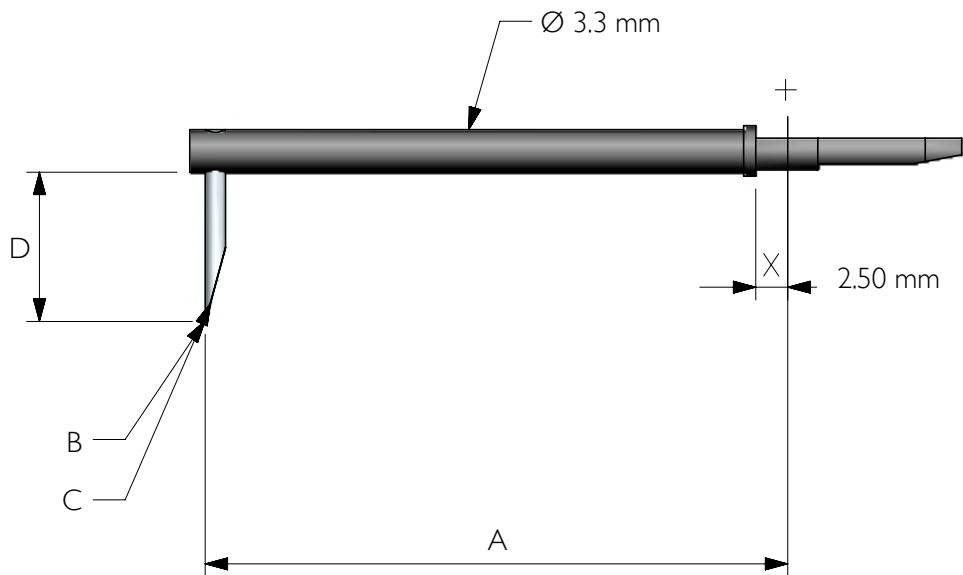

Part no.	Effective length A (mm)	Tip cone angle B (Deg)	Tip radius C (µm)	Shank clearance D (mm)	Tip
112-2013	60	90	2	5.30	Diamond chisel
155-P56924	120	15	20	17.00	Tungsten carbide chisel

## Form Talysurf® Inductive (1 & 2 mm) - Small bore styli

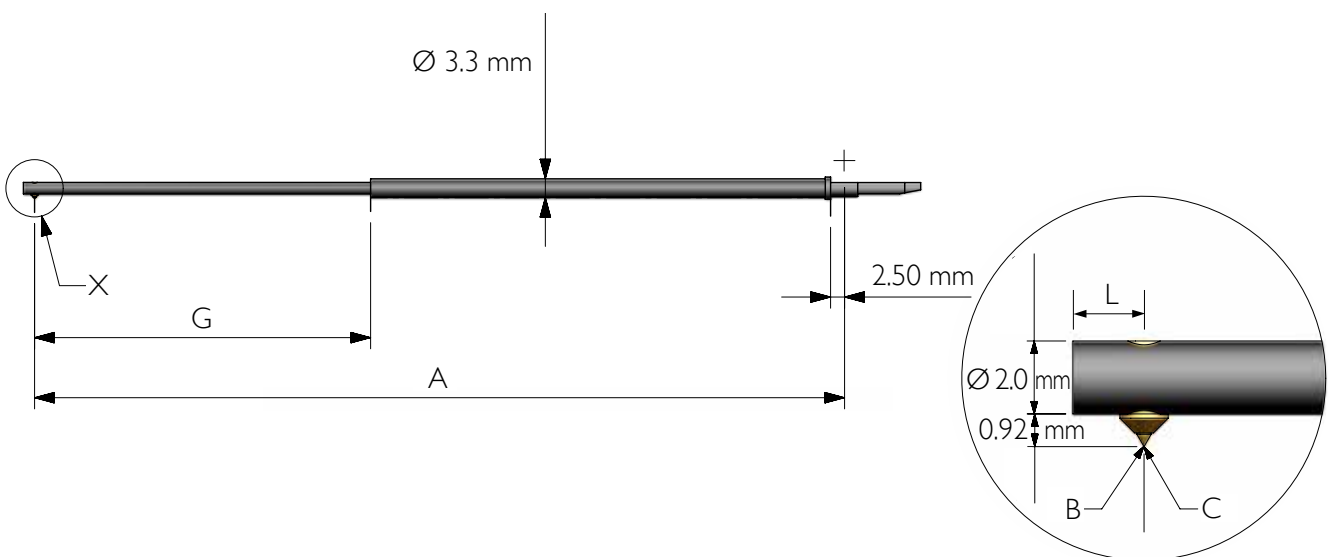

Part no.	Effective length A (mm)	Tip cone angle B (Deg)	Tip radius C (µm)	Stem reach G (mm)	Tip distance L (mm)	Tip
155-P36892	60	90	2	30.00	2.5	Diamond conisphere
155-P53341	90	90	2	58.00	2.5	Diamond conisphere

## Form Talysurf® Inductive (1 & 2 mm) - Miniature bore styli

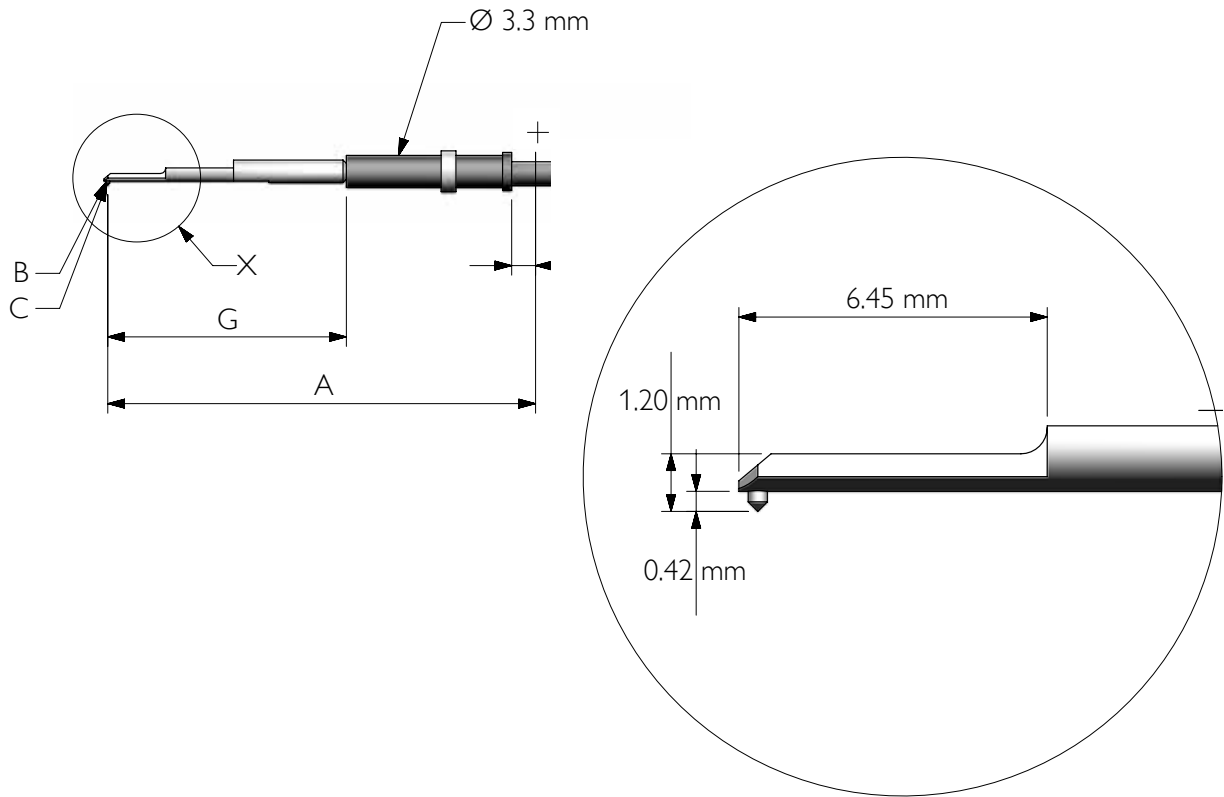

Part no.	Effective length A (mm)	Tip cone angle B (Deg)	Tip radius C ( $\mu$ m)	Stem reach G (mm)	Tip
112-2012	60	90	2	25.00	Diamond conisphere
155-P58134	60	90	2	33.00	Diamond conisphere
155-P33670	120	90	2	25.00	Diamond conisphere

## Form Talysurf® Inductive (5 mm) - Recess styli

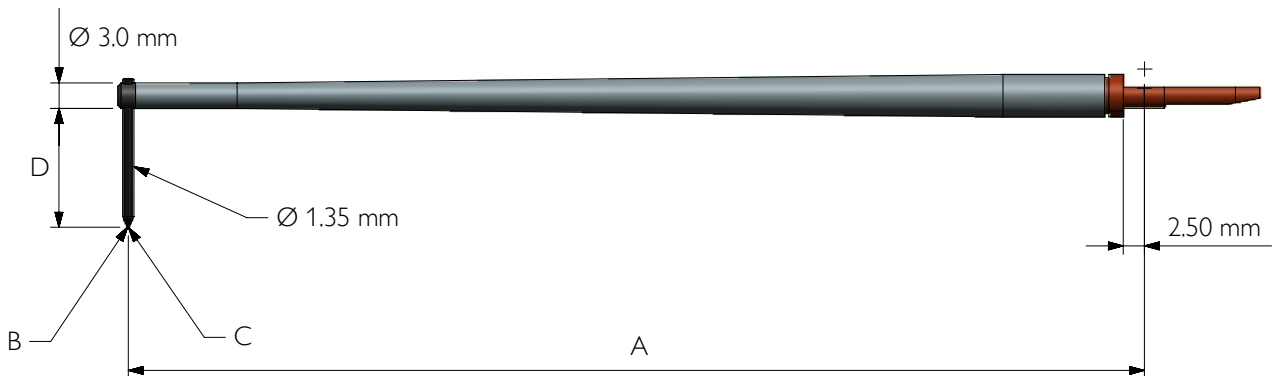

Part no.	Effective length A (mm)	Tip cone angle B (Deg)	Tip radius C ( $\mu\text{m}$ )	Shank clearance D (mm)	Tip
1 112-4575	120	90	2	14.00	Diamond conisphere
112-4576	120	90	2	5.30	Diamond conisphere
112-4908	120	90	5	5.30	Diamond conisphere
112-4593	120	60	2	14.00	Diamond conisphere
112-4921	120	60	5	14.00	Diamond conisphere
112-4594	120	60	2	5.30	Diamond conisphere
155-P60328	120	90	2	25.00	Diamond conisphere
112-4579	120	-	500	14.00	Ruby ball
112-4578	120	90	2	14.00	Diamond chisel

## Form Talysurf® Inductive (5 mm) - Small bore styli

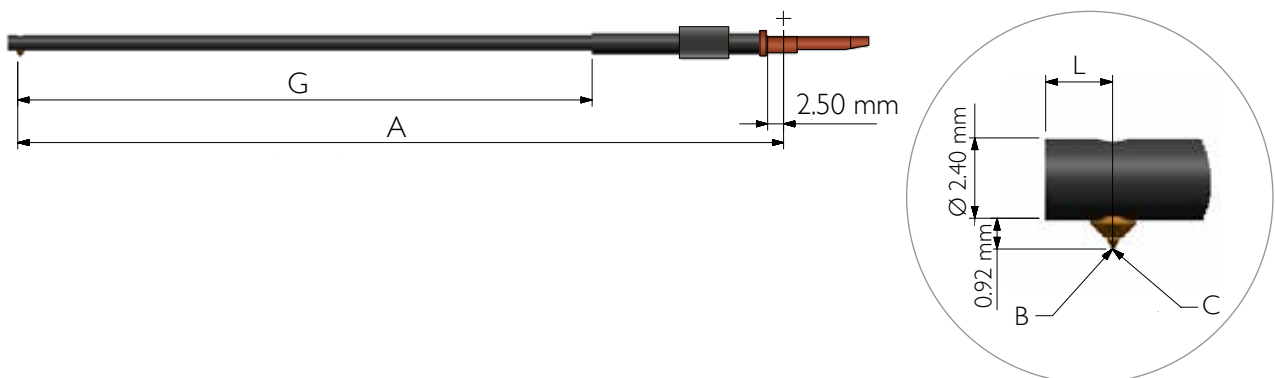

Part no.	Effective length A (mm)	Tip cone angle B (Deg)	Tip radius C ( $\mu\text{m}$ )	Stem reach G (mm)	Tip distance L (mm)	Tip
115-60338	120	90	2	90.00	2	Diamond conisphere



## Form Talysurf® Inductive (5 mm) - Small bore styli

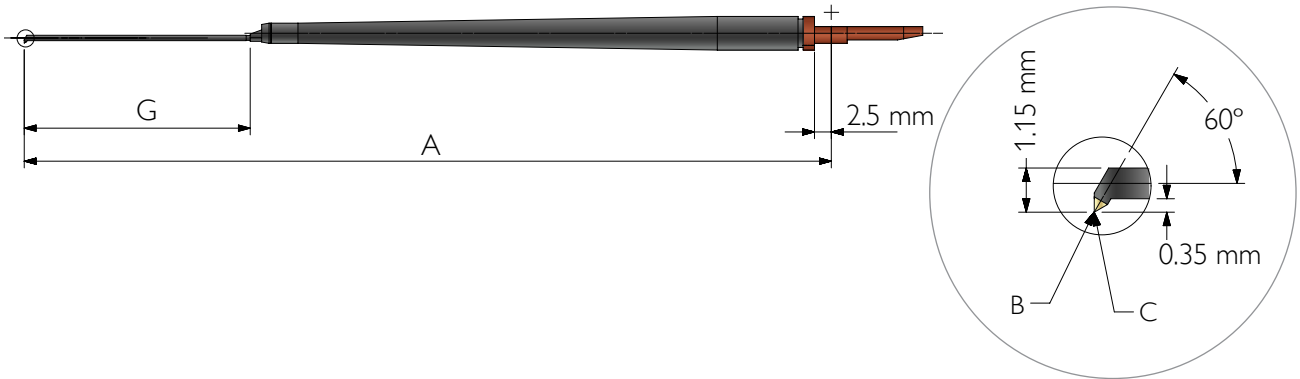

Part no.	Effective length A (mm)	Tip cone angle B (Deg)	Tip radius C (μm)	Stem reach G (mm)	Tip
112-4577	120	60	2	34.00	Diamond conisphere

## Form Talysurf® Inductive (5 mm) - Miniature bore styli

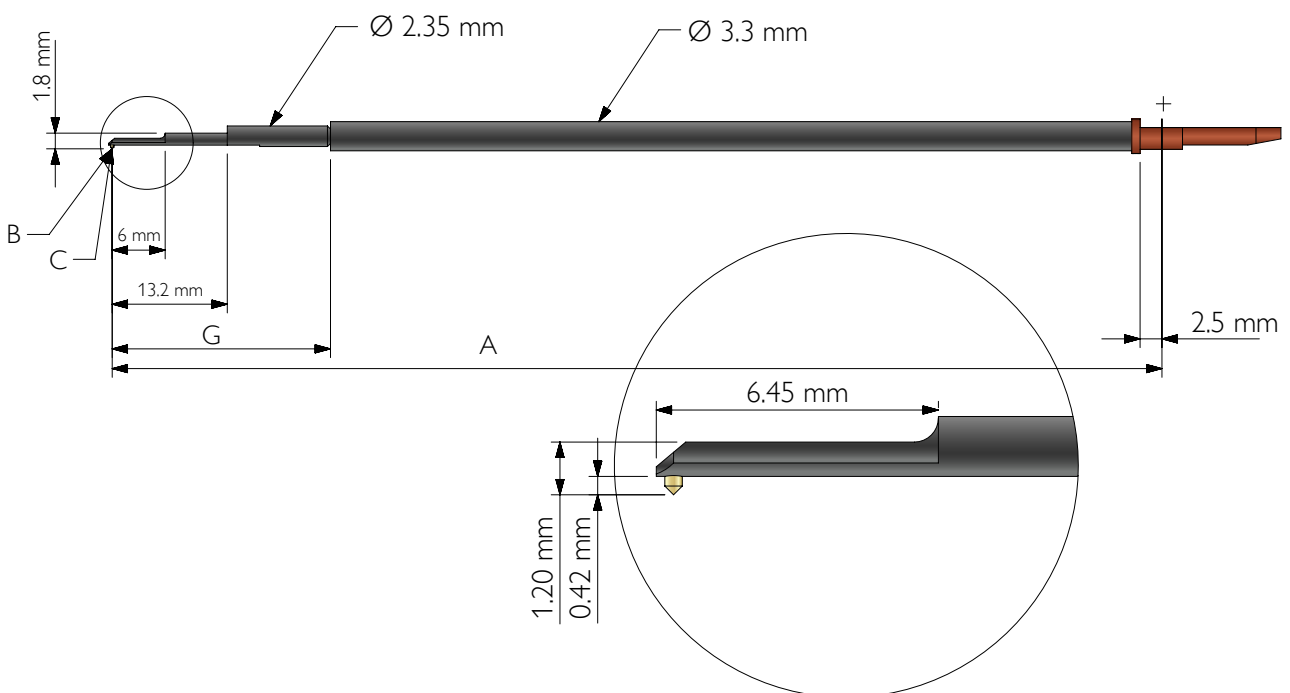

Part no.	Effective length A (mm)	Tip cone angle B (Deg)	Tip radius C (μm)	Stem reach G (mm)	Tip
112-5434	120	90	2	25.00	Diamond conisphere

# Instrument Styli

## Wide Range - Recess chisel styli

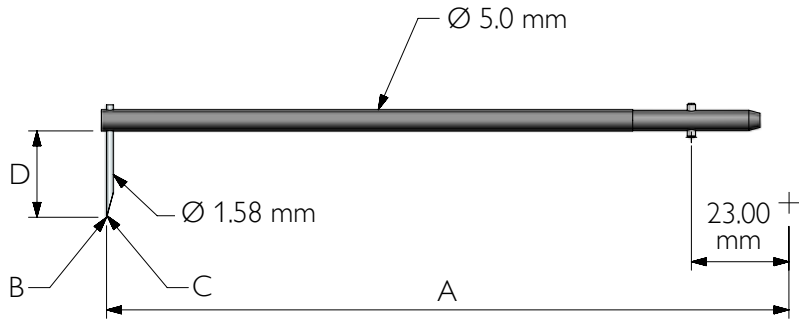

Part no.	Effective length A (mm)	Tip cone angle B (Deg)	Tip radius C ( $\mu\text{m}$ )	Shank clearance D (mm)	Tip
K501-1684	160	15	20	21.50	Tungsten carbide chisel

## Wide Range - Recess conical styli

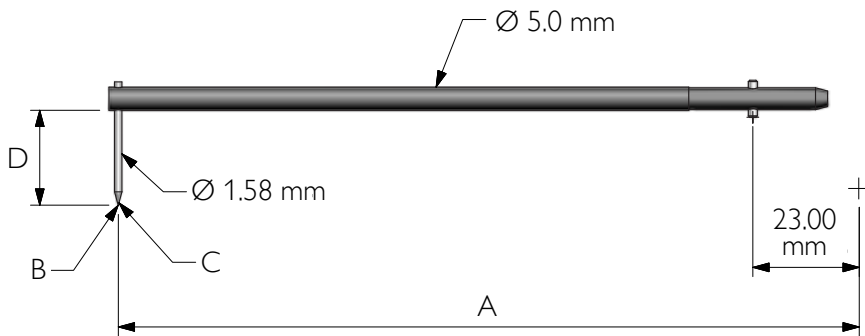

Part no.	Effective length A (mm)	Tip cone angle B (Deg)	Tip radius C ( $\mu\text{m}$ )	Shank clearance D (mm)	Tip
K501-1685	160	30	20	21.50	Tungsten carbide

## Wide Range - Recess ball styli

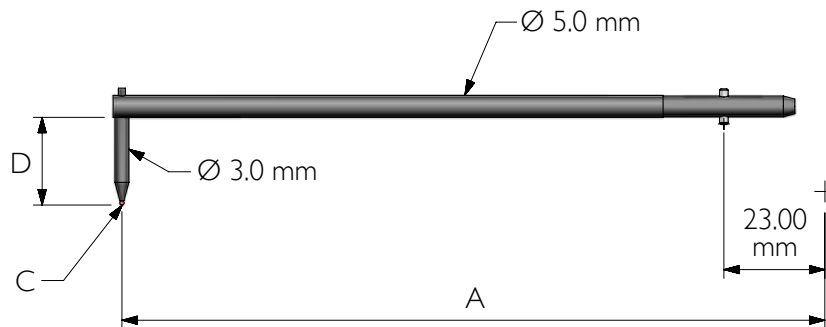

Part no.	Effective length A (mm)	Tip radius C ( $\mu\text{m}$ )	Shank clearance D (mm)	Tip
K501-1686	160	500	0.50	Ruby ball

## Form Talysurf® PGI - Recess styli

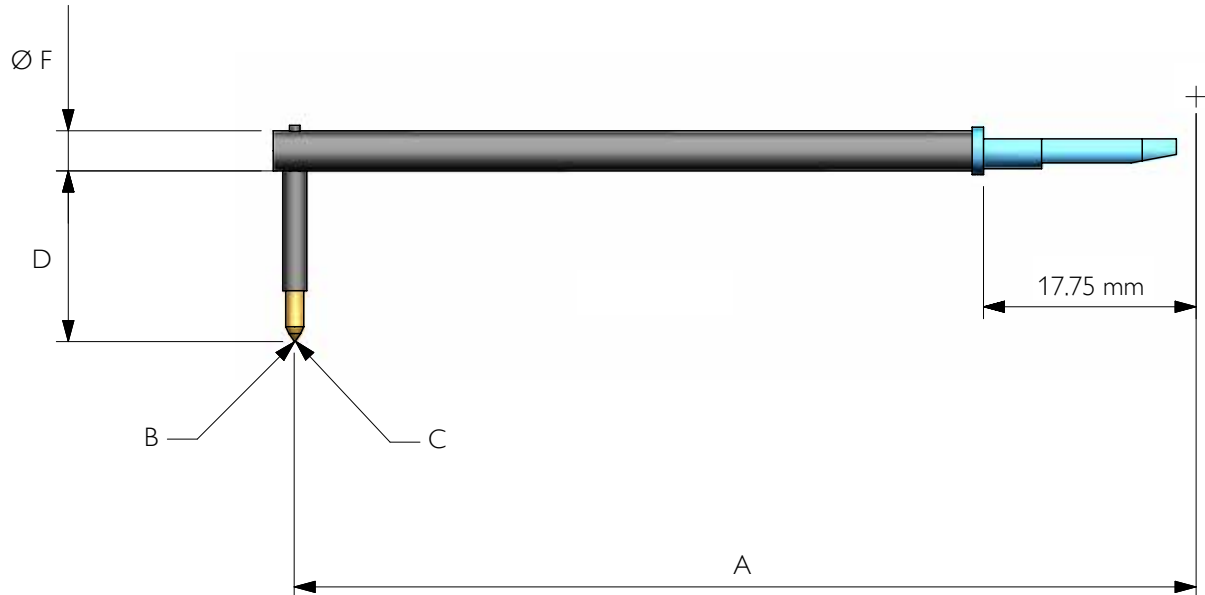

Part no.	Effective length A (mm)	Tip cone angle B (Deg)	Tip radius C ( $\mu\text{m}$ )	Shank clearance D (mm)	Beam diameter F (mm)	Tip
112-3412	60	40	2	12.20	3.3	Diamond conisphere
155-P56559	60	40	5	12.20	3.3	Diamond conisphere
155-P58044	60	60	2	10.00	3.3	Diamond conisphere
112-3227	60	60	2	12.20	3.3	Diamond conisphere
112-3221	60	90	2	12.20	3.3	Diamond conisphere
155-P57540	60	90	2	15.00	3.3	Diamond conisphere
112-3224	60	90	5	24.95	3.3	Diamond conisphere
112-3410	60	-	150	12.20	5.0	Ruby ball
112-3228	60	-	500	13.05	5.0	Ruby ball
155-P54469	120	90	2	12.20	3.3	Diamond conisphere
112-3405	120	-	400	19.00	5.0	$\text{Si}_3\text{N}_4$ ball
155-P57136	120	-	500	12.50	3.3	Ruby ball
112-3161	120	-	500	31.00	5.0	Ruby ball
112-3162	150	-	500	31.00	5.0	Ruby ball
112-3269	180	-	500	32.00	5.0	Ruby ball

# Instrument Styli

## Form Talysurf® PGI - Forward pointing recess styli

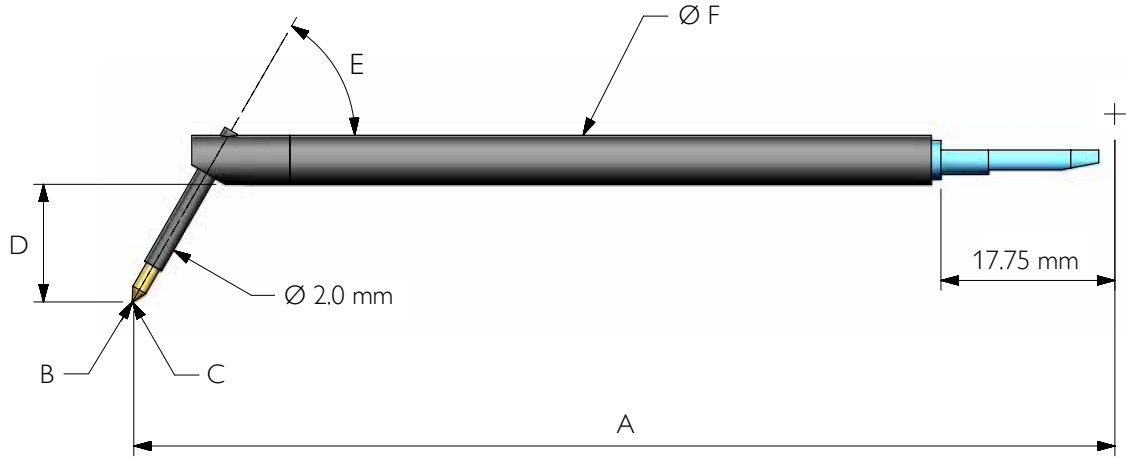

Part no.	Effective length A (mm)	Tip cone angle B (Deg)	Tip radius C ( $\mu\text{m}$ )	Shank clearance D (mm)	Shank angle E (Deg)	Beam diameter F (mm)	Tip
155-P57763	60	-	150	4.93	30	3.3	Si <sub>3</sub> N <sub>4</sub> ball
155-P57322	120	40	2	15.00	70	3.3	Diamond conisphere

## Form Talysurf® PGI - Small bore styli

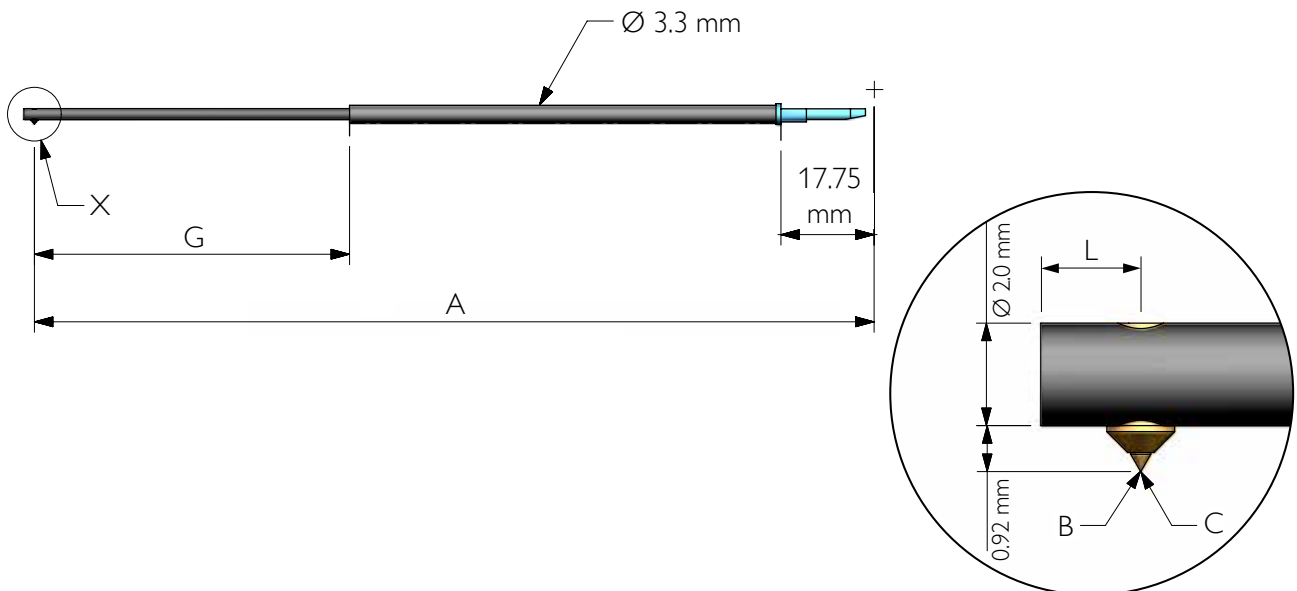

Part no.	Effective length A (mm)	Tip cone angle B (Deg)	Tip radius C ( $\mu\text{m}$ )	Stem reach G (mm)	Tip distance L (mm)	Tip
155-P54307	60	60	2	15.00	1.5	Diamond conisphere
112-3222	60	90	2	15.00	1.5	Diamond conisphere

## Form Talysurf® PGI - Miniature bore styli

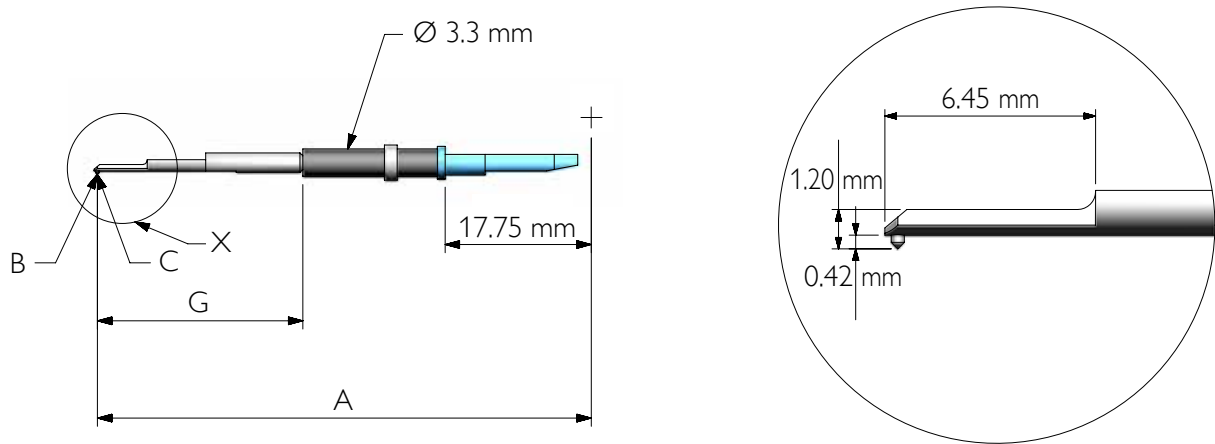

Part no.	Effective length A (mm)	Tip cone angle B (Deg)	Tip radius C ( $\mu\text{m}$ )	Stem reach G (mm)	Tip
155-P54957	60	60	2	25.00	Diamond conisphere
155-P58057	120	90	2	25.00	Diamond conisphere

## Form Talysurf® PGI - Nozzle styli

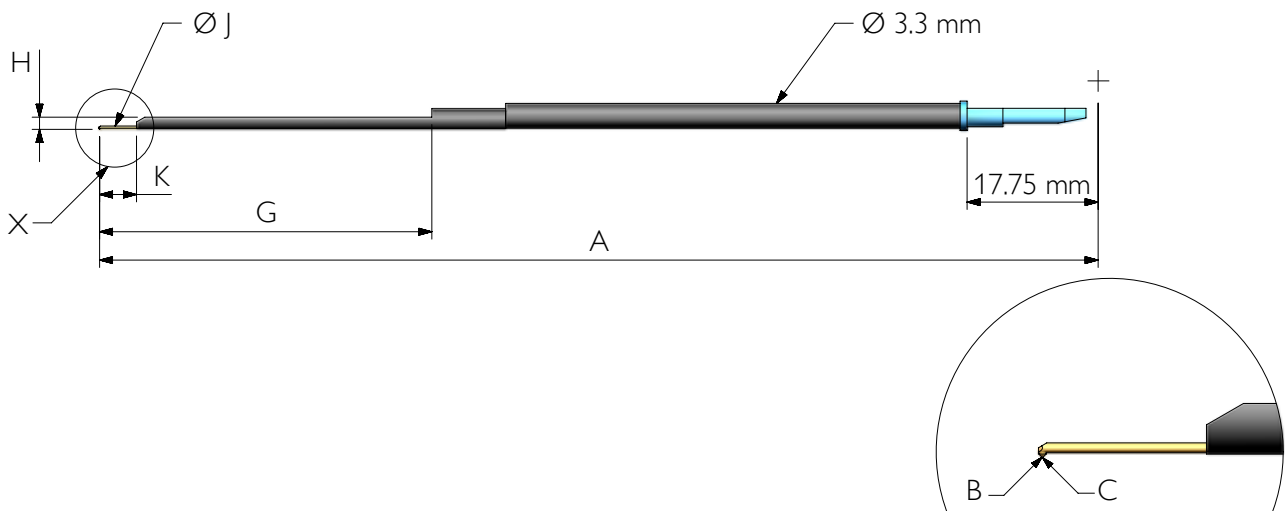

Part no.	Effective length A (mm)	Tip cone angle B (Deg)	Tip radius C ( $\mu\text{m}$ )	Tip reach K (mm)	Total clearance H (mm)	Stem reach G (mm)	Tip diameter J (mm)	Tip
155-P56232	60	90	2	10.00	2.60	25.00	0.65	Diamond conisphere
155-P57185	90	60	2	5.00	1.75	45.00	0.45	Diamond conisphere
155-P58426	90	60	2	5.00	1.95	45.00	0.45	Diamond conisphere
155-P56519	105	60	2	5.00	1.75	45.00	0.65	Diamond conisphere

## Form Talysurf® PGI (1000, 1500 & 2000) - Recess styli



Part no.	Effective length A (mm)	Tip cone angle B (Deg)	Tip radius C (µm)	Shank clearance D (mm)	Beam diameter F (mm)	Tip
112-5099	100	90	2	15.75	3.3	Diamond conisphere
112-5205	100	60	2	15,75	3.3	Diamond conisphere
112-5206	100	40	5	15.75	3.3	Diamond conisphere
112-5207	100	90	5	15.75	3.3	Diamond conisphere
112-5210	100	90	5	24.95	3.3	Diamond conisphere
112-5214	100	40	2	15.75	3.3	Diamond conisphere
112-5215	100	-	500	13.05	5	Ruby ball
112-5216	100	-	150	15.75	5	Ruby ball
112-5217	100	-	400	12.2	5	Ruby ball
112-5495	120	-	150	19	5	Ruby ball
112-5496	120	-	400	19	5	Ruby ball
112-5497	150	-	500	31.5	5	Ruby ball
112-5498	180	-	500	34.5	5	Ruby ball

## Form Talysurf® PGI (1000, 1500 & 2000) - Small bore styli

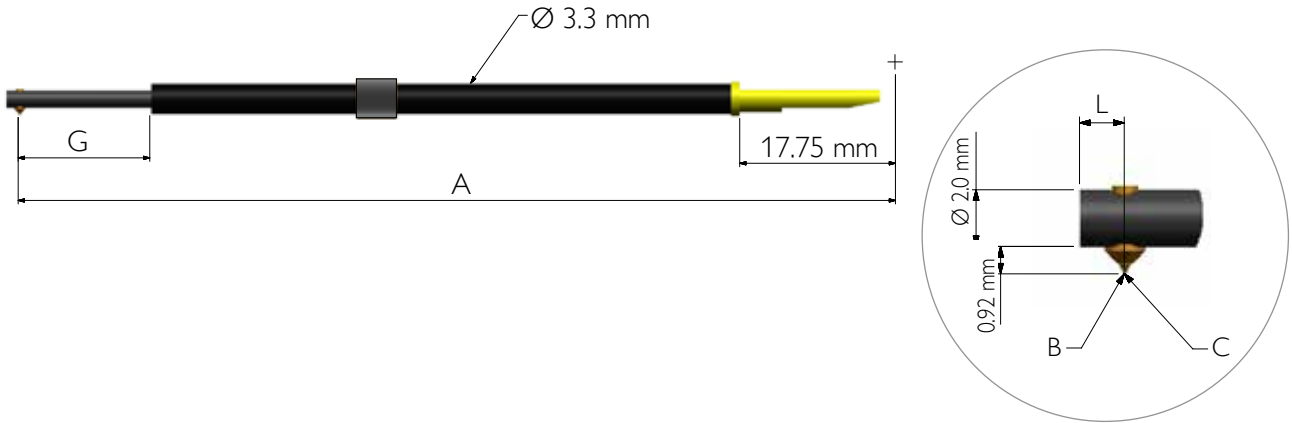

Part no.	Effective length A (mm)	Tip cone angle B (Deg)	Tip radius C ( $\mu$ m)	Stem reach G (mm)	Tip
112-5208	100	90	2	15.00	Diamond conisphere

## Form Talysurf® PGI (1000, 1500 & 2000) - Miniature bore styli

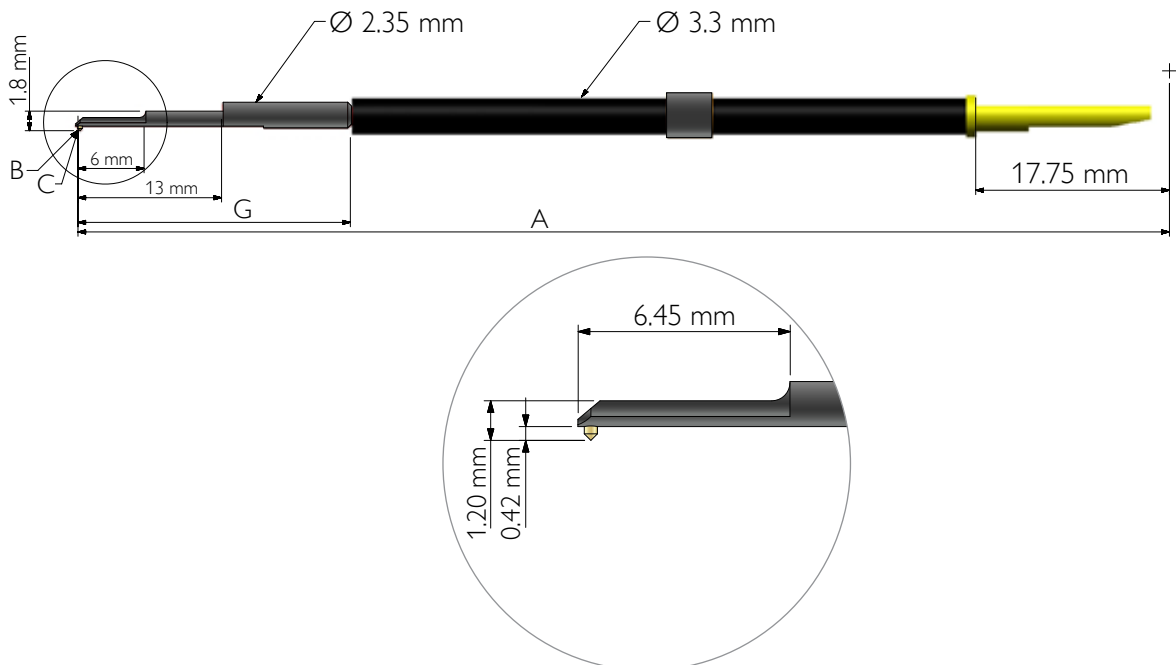

Part no.	Effective length A (mm)	Tip cone angle B (Deg)	Tip radius C ( $\mu$ m)	Stem reach G (mm)	Tip
112-5209	100	90	2	25.00	Diamond conisphere

# Instrument Styli

## Form Talysurf® PGI (1000, 1500 & 2000) - Front facing styli

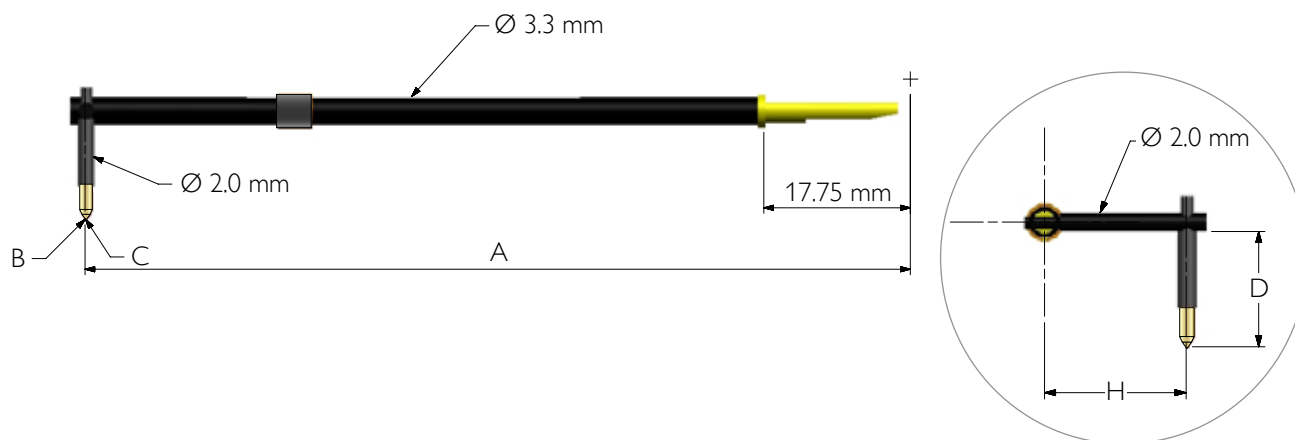

Part no.	Effective length A (mm)	Tip cone angle B (Deg)	Tip radius C ( $\mu\text{m}$ )	Shank clearance D (mm)	Off-set H (mm)	Tip
112-5212	100	90	5	12.20	15.00	Diamond conisphere

## Form Talysurf® PGI (1000, 1500 & 2000) - Rear facing styli

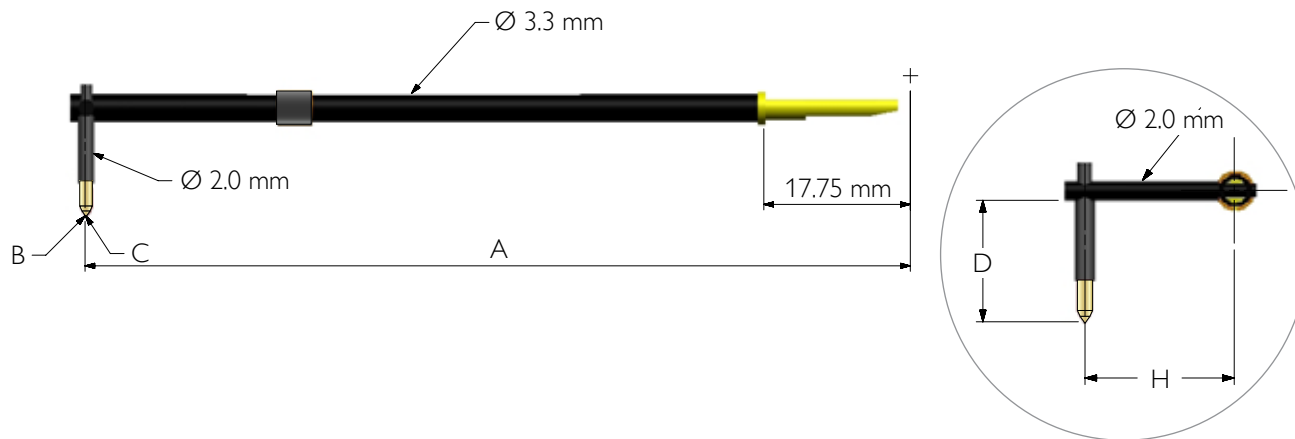

Part no.	Effective length A (mm)	Tip cone angle B (Deg)	Tip radius C ( $\mu\text{m}$ )	Shank clearance D (mm)	Off-set H (mm)	Tip
112-5213	100	90	5	12.20	15.00	Diamond conisphere



## Form Talysurf® PGI NOVUS (Single bias) - Recess styli

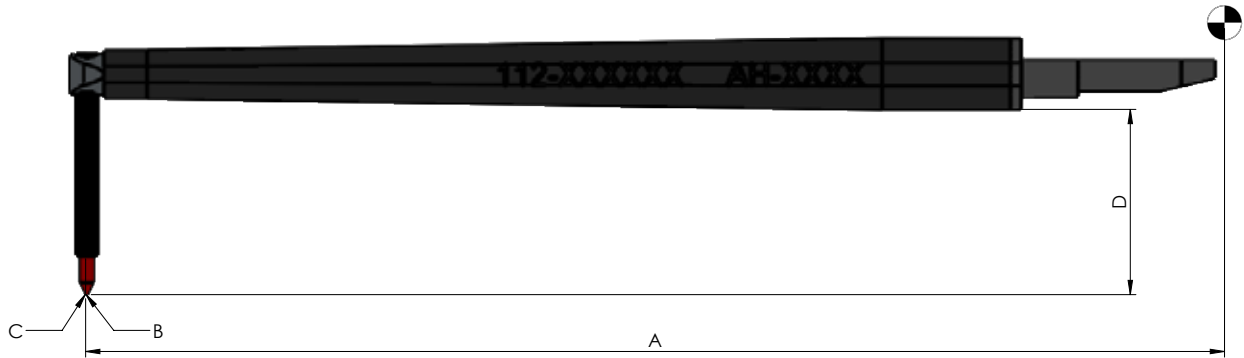

Part no.	Effective length A (mm)	Tip cone angle B (Deg)	Tip radius C (μm)	Shank clearance D (mm)	Tip
112-100648	100	60	2	16.25	Diamond conisphere
112-100651	100	60	5	16.25	Diamond conisphere
112-100655	100	60	2	25	Diamond conisphere
112-100659	100	60	5	25	Diamond conisphere
112-100668	200	60	2	16.25	Diamond conisphere
112-100671	200	60	5	16.25	Diamond conisphere
112-100674	200	60	2	25	Diamond conisphere
112-100677	200	60	5	25	Diamond conisphere
112-100657	100	40	2	25	Diamond conisphere
112-100661	100	40	5	25	Diamond conisphere
112-100670	200	40	2	16.25	Diamond conisphere
112-100673	200	40	5	16.25	Diamond conisphere
112-100676	200	40	2	25	Diamond conisphere
112-100679	200	40	5	25	Diamond conisphere
112-102475	100	60	2	0.65°	Diamond conisphere
112-102523	100	60	2	0.15°	Diamond conisphere
112-100690	100	-	0.5	25	Ruby Ball
112-100696	200	-	0.5	16.25	Ruby Ball
112-100698	200	-	0.25	25	Ruby Ball
112-100699	200	-	0.5	25	Ruby Ball
112-100687	100	-	0.5	16.25	Ruby ball

\* Tip shank clearance.

## Form Talysurf® PGI NOVUS (Dual bias) - Recess styli

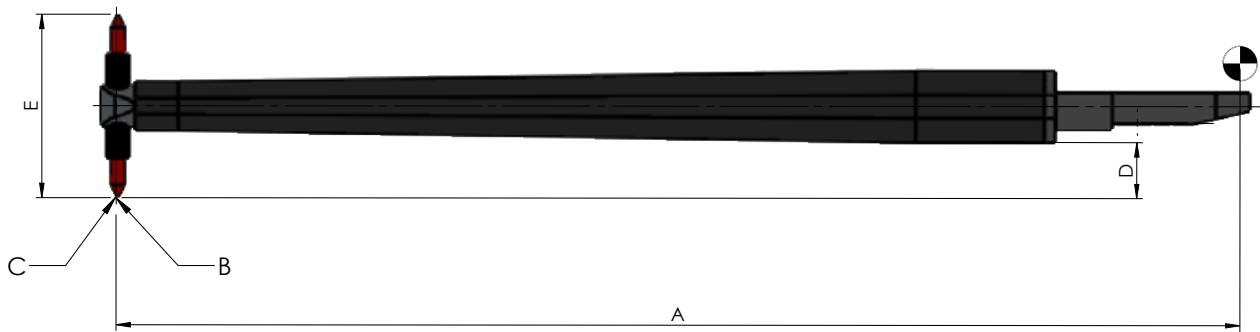

Part no.	Effective length A (mm)	Tip cone angle B (Deg)	Tip radius C (µm)	Shank clearance D (mm)	Tip to tip E (mm)	Tip
112-100700	100	60	2	4.88	16	Diamond conisphere
112-100702	100	60	5	4.88	16	Diamond conisphere
112-100713	200	60	2	4.88	16	Diamond conisphere
112-100715	200	60	5	4.88	16	Diamond conisphere
112-100709	200	60	2	13.25	32	Diamond conisphere
112-100711	200	60	5	13.25	32	Diamond conisphere
112-100869	100	60	2	16.25	38.75	Diamond conisphere
112-101034	100	60	5	16.25	38.75	Diamond conisphere
112-101144	100	60	2	0.15°	0.8	Diamond conisphere
112-101143	100	60	2	0.65°	2.8	Diamond conisphere
112-101779	100	60	2	2.88	12	Diamond conisphere
112-100729	200	-	0.5	13.3	32	Ruby Ball
112-100732	200	-	0.5	5.25	16	Ruby Ball
112-103121	100	-	0.5	16.25	38.75	Ruby Ball

## Talyrond® Talymin (4, 5 & 6) - Standard ball styli

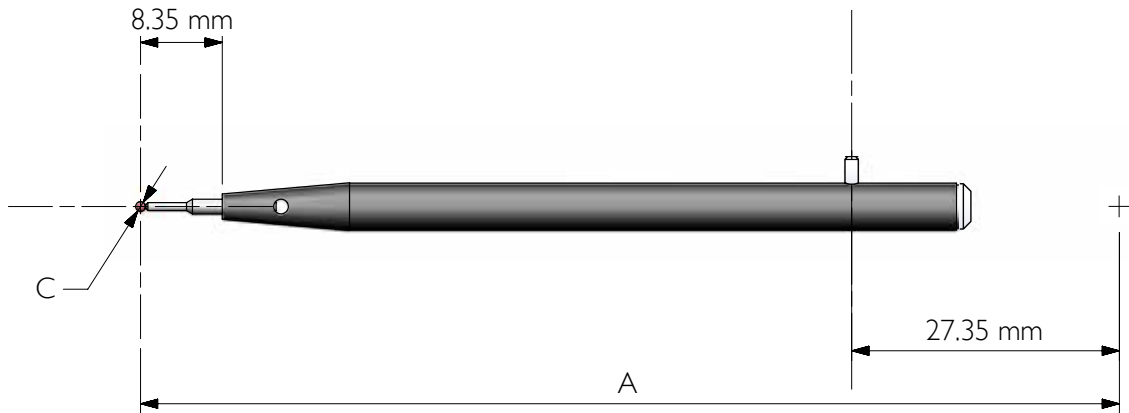

Part no.	Effective length A (mm)	Tip radius C (mm)	Tip
155-P54495	100	0.25	Ruby ball
155-P54342	100	0.40	Ruby ball
112-3245	100	0.50	Ruby ball
112-3244	100	1.00	Sapphire ball
112-3243	100	2.00	Ruby ball
155-P54248	150	1.00	Sapphire ball
155-P30358*	152.5	1.00	Sapphire ball
155-P54851	200	1.00	Sapphire ball
155-P37074*	200	1.00	Sapphire ball

## Talyrond® Talymin (4, 5 & 6) - Ball recess styli

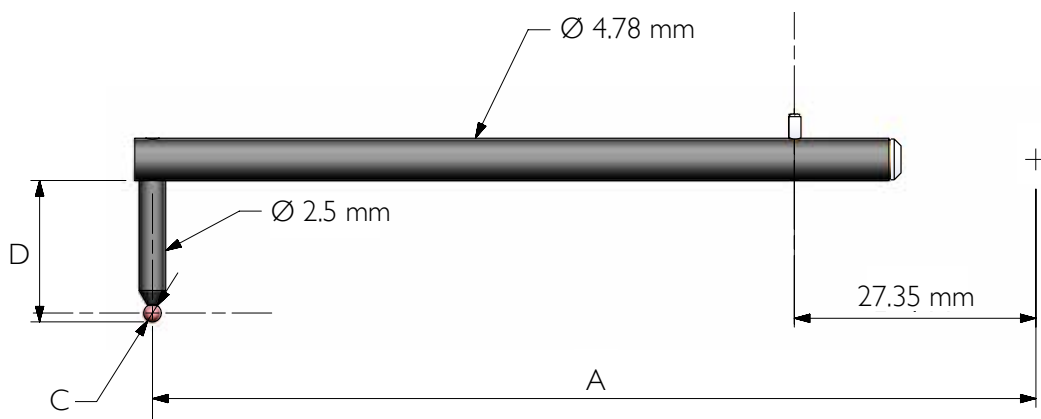

Part no.	Effective length A (mm)	Tip radius C (mm)	Shank clearance D (mm)	Tip
155-P56176	100	0.25	10.00	Ruby ball
155-P56500	100	1.00	5.00	Ruby ball
155-P56217	200	1.00	2.00	Ruby ball

\* Talymin 4 stylus.

## Talyrond® Talymin (4, 5 & 6) - Diamond recess styli

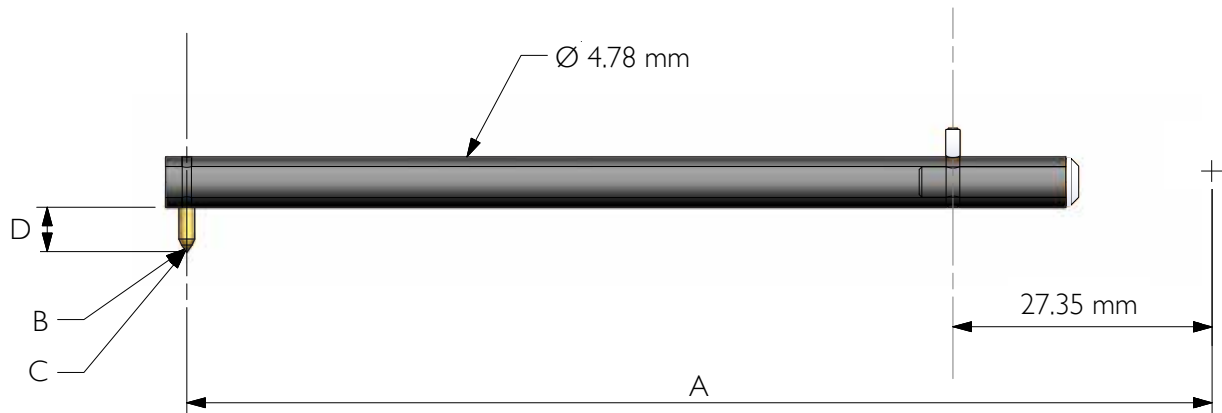

Part no.	Effective length A (mm)	Tip cone angle B (mm)	Tip radius C (μm)	Shank clearance D (mm)	Tip
112-3806	100	90	5	4.25	Diamond conisphere
112-3807	100	90	10	4.25	Diamond conisphere

## Talyrond® Talymin (4, 5 & 6) - Reach recess styli

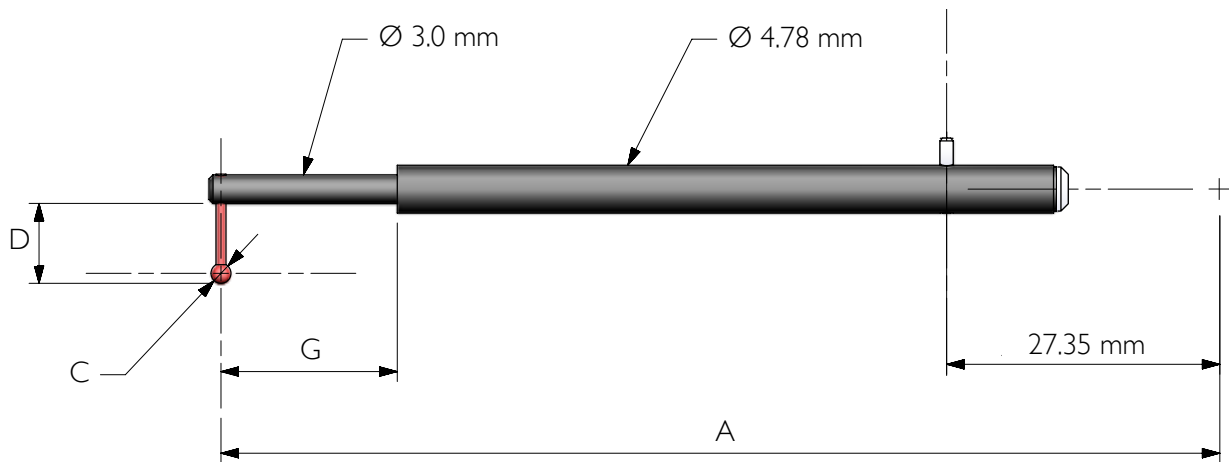

Part no.	Effective length A (mm)	Tip radius C (mm)	Shank clearance D (mm)	Stem reach G (mm)	Tip
155-P56376	100	0.50	5.00	21.50	Ruby ball
155-P54207	100	0.50	8.00	21.50	Ruby ball
155-P57644	100	1.00	2.00	22.0	Ruby ball
155-P56205	100	1.00	10.00	25.00	Ruby ball
155-P54420	100	1.00	15.00	25.00	Ruby ball
155-P56152	150	1.00	5.00	20.00	Ruby ball
155-P56173	200	1.00	5.00	21.50	Ruby ball

## Talyrond® Talymin (4, 5 & 6) - Reach styli

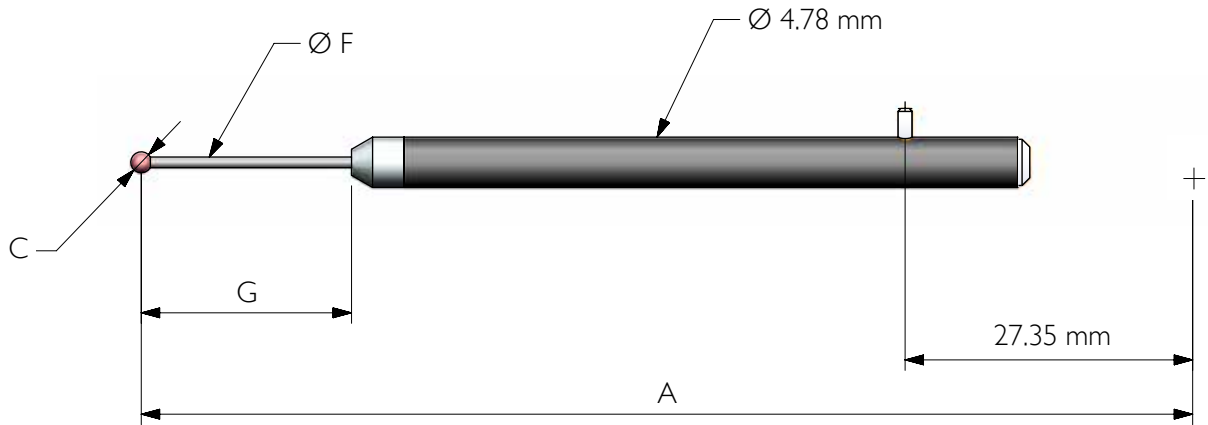

Part no.	Effective length A (mm)	Tip radius C (mm)	Reach tube diameter F (mm)	Stem reach G (mm)	Tip
155-P56376	100	0.75	1.00	40.00	Ruby ball
155-P54207	100	0.50	0.50	26.00	Ruby ball
155-P57644	100	0.40	1.50	40.00	Ruby ball
155-P56205	100	0.40	0.50	10.00	Ruby ball
155-P54420	100	0.15	1.00	1-00	Ruby ball

## Talyrond® Talymin (4, 5 & 6) - Forward pointing recess styli

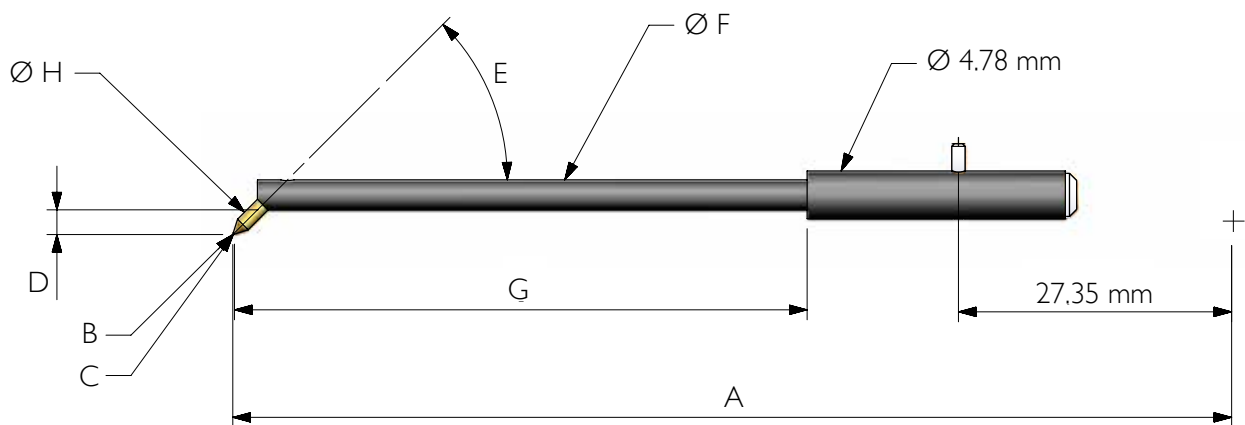

Part no.	Effective length A (mm)	Tip cone angle B (Deg)	Tip radius C (mm)	Shank clearance D (mm)	Shank angle E (Deg)	Reach tube diameter F (mm)	Stem reach G (mm)	Shank diameter H (mm)	Tip
155-P57992	100	30	100	0.40	30	2.00	54.00	0.40	Tungsten carbide

# Instrument Styli

## Talyrond® Talymin (4, 5 & 6) - Diamond recess styli

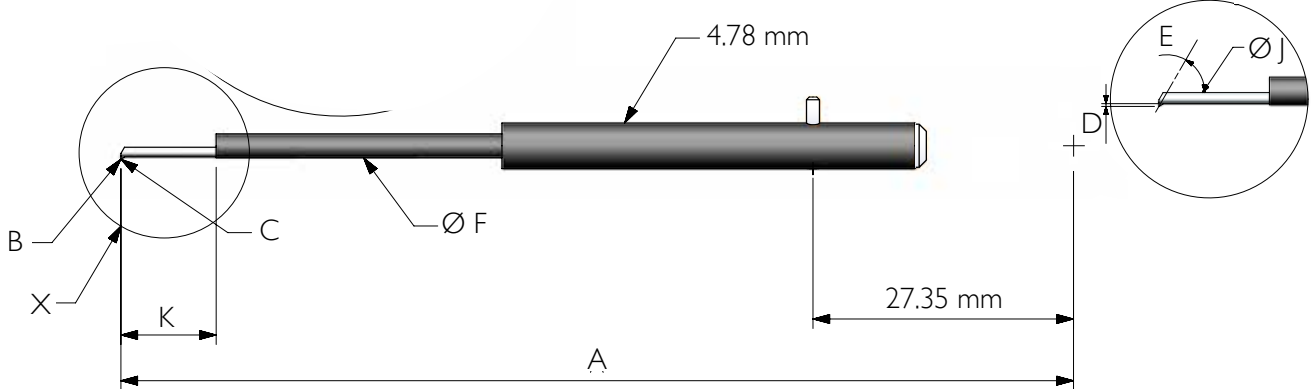

Part no.	Effective length A (mm)	Tip cone angle B (Deg)	Tip radius C (mm)	Shank clearance D (mm)	Shank angle E (Deg)	Stem reach K (mm)	Reach tube diameter F (mm)	Stem diameter J (mm)	Tip
155-P58637	150	60	5	0.25	45	10.00	1.00	1.00	Diamond conisphere

## Talyrond® Talymin (4, 5 & 6) - Reach recess styli

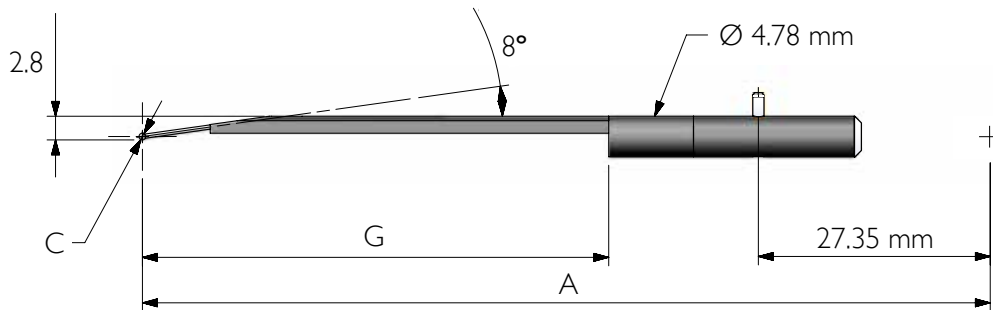

Part no.	Effective length A (mm)	Tip radius C (mm)	Reach G (mm)	Tip
155-P58747	100	0.40	55.00	Ruby ball
155-P55101	100	0.30	48.00	Ruby ball

## Talyrond® Talymin (4, 5 & 6) - Bar styli

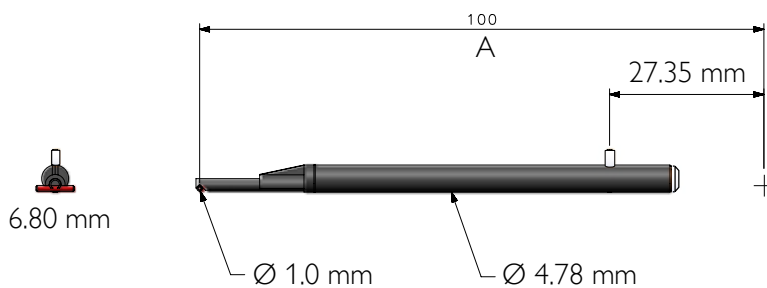

Part no.
155-P58747
Effective length A (mm)
100
Tip
Ruby ball

## Talyrond® Talymin - Multi-tip styli (Special)

Taylor Hobson has over 3000 styli designs available

There are 3 categories of Styli:

- **Standard**

Recess Ball or 90° 2 µm Diamond stylus as supplied with the instrument as standard.

- **Advanced**

Small bore, Minature bore or 60° diamond styli, available to purchase off the shelf with or after instrument sale.

- **Special**

Styli, designed and manufactured to customers exact requirements, usually specific to customers components or setup.

### Special styli for roundness applications

Taylor Hobson's custom styli design service can build multi-tip styli for your specific component, therefore reducing operator intervention as there is no need to change styli during an automated routine. Further benefits of multi-tip styli include improved accuracy, reduced measurement times and increased yeild.

Multi-tip Talymin styli examples illustrated below. Please speak with our 'Centre of Excellence' team to discuss how we can help improve your measurement processes by using multi-tip styli and automated measurement programs.

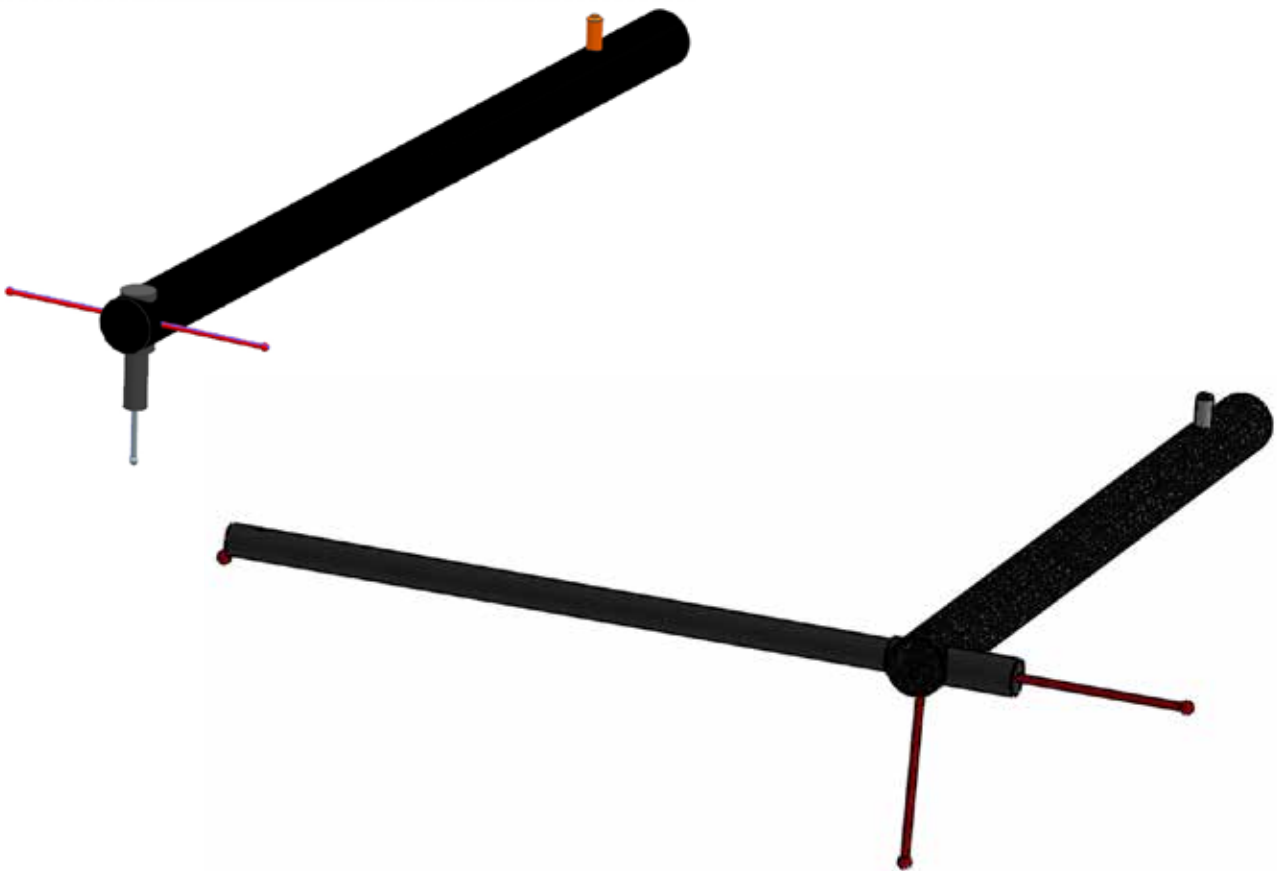

## Y-axis stages (standard, large or with V assembly)



Translation Stages are used to provide accurate movement across one or more axes of mounted parts for a range of applications. Parts can be easily moved or repositioned without the need for removal or recalibration.

They are key to any system that requires fast or precise movement of parts. Stages may also be linked together to provide additional axes of movement beyond their individual capabilities for increased versatility.

Part no.	Adjustment range	For use with	Load capacity	Weight	Platform area (W x L)	Vee plate size (W x L)	Dimensions (W x L x H)
112-3163	25 mm (1.0 in)	T-slots	30 kg (66 lbs)	1.9 kg (4 lbs)	120 x 120 mm (4.7 x 4.7 in)	-	218 x 180 x 40 mm (8.6 x 7.1 x 1.6 in)
112-4091	25 mm (1.0 in)	Rotary tables	30 kg (66 lbs)	Available on request	120 x 120 mm (4.7 x 4.7 in)	-	Available on request
112-1826	25 mm (1.0 in)	T-slots	50 kg (110 lbs)	11 kg (24 lbs)	200 x 200 mm (7.9 x 7.9 in)	-	200 x 215 x 40 mm (7.9 x 8.5 x 1.6 in)
112-4923	50 mm (2.0 in)	T-slots	50 kg (110 lbs)	20 kg (44 lbs)	280 x 280 mm (11 x 11 in)	-	280 x 300 x 40 mm (11.0 x 11.8 x 1.6 in)
112-3067	25 mm (1.0 in)	-	25 kg (55 lbs)	2.4 kg (5 lbs)	-	90 x 90 mm (3.5 x 3.5 in)	140 x 180 x 80 mm (5.5 x 7.1 x 3.1 in)

## 3D stage / Precision translation stage (X-Y-θ)



**Precision translation stage** - Complete stage assembly to provide X, Y, Z, rotary and tilting positioning moves. Includes vee block and location plate for mounting to the T slot in the granite base.

**Y-axis table with V plate** - Simple stage assembly with Y axis positioning, vee block and location plate for mounting in the granite base.

Part no.	X/Y range	Z range	θ range	Load capacity	Weight	Platform area (W x L)	Vee plate size (W x L)	Dimensions (W x L x H)
112-4902	25 mm (1.0 in)	-	±5°	50 kg (110 lbs)	15 kg (33 lbs)	170 x 170 mm (6.7 x 6.7 in)	-	Available on request
112-3064	25 mm (1.0 in)	5 mm (1.0 in)	-	Available on request	Available on request	-	90 x 90 mm (3.5 x 3.5 in)	Available on request



## Motorized stages (Linear or rotary)



The motorized linear stage has a pre-loaded ball screw to ensure high stiffness and minimum backlash, this delivers very small adjustment increments at high positioning speeds. The high precision linear stage is suitable for all applications that require excellent flatness, very small tolerances and smooth movement.

The high precision rotary stage can be combined with the linear stage to form sophisticated multi-axis systems which achieves outstanding levels of accuracy.

Part no.	Part no. (GEP)	Adjustment range	Configuration	Load capacity	Weight	Platform area (W x L)	Dimensions (W x L x H)
112-5342	112-102576	100 mm (4.0 in)	Stage only	20 kg (44 lbs)	4.3 kg (9 lbs)	120 x 140 mm (4.7 x 5.5 in)	160 x 315 x 40 mm (6.3 x 12.4 x 1.6 in)
112-5353	112-102577	100 mm (4.0 in)	Stage with mounting plate	20 kg (44 lbs)	4.3 kg (9 lbs)	120 x 140 mm (4.7 x 5.5 in)	160 x 315 x 40 mm (6.3 x 12.4 x 1.6 in)
112-5347	112-102578	200 mm (8.0 in)	Stage only	20 kg (44 lbs)	5.3 kg (12 lbs)	120 x 140 mm (4.7 x 5.5 in)	160 x 460 x 40 mm (6.3 x 18.1 x 1.6 in)
112-5422	112-102579	200 mm (8.0 in)	Stage with mounting plate	20 kg (44 lbs)	5.3 kg (12 lbs)	120 x 140 mm (4.7 x 5.5 in)	160 x 460 x 40 mm (6.3 x 18.1 x 1.6 in)
112-5343	112-102580	360°	Stage only	10 kg (22 lbs)	4.5 kg (10 lbs)	Ø170	200 x 240 x 40 mm (7.9 x 9.4 x 1.6 in)
112-5429	112-102581	360°	Stage with vertical mounting plate	10 kg (22 lbs)	4.5 kg (10 lbs)	Ø170	200 x 240 x 40 mm (7.9 x 9.4 x 1.6 in)

## Crankshaft Y-axis stage (large, heavy-duty or tilting)

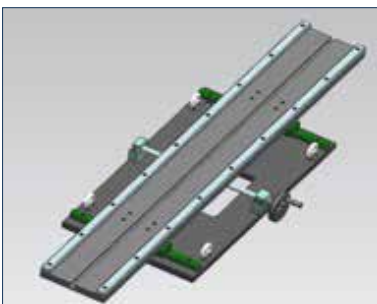

The Crankshaft Fixture has a central tee slot, additional fixtures such as vee block pairs, roller vee pairs or other component supports can be inserted to accommodate a range of components. Primarily intended for use with Large Granite Form Talysurf® Air slide systems or 1200 mm granite table (112-4229).

The fixture is used to locate components in the correct orientation for surface texture and form measurements, taken along the component axis using a gauge with a right angle attachment. The manual Y-axis travel enables accurate cresting of the components, essential for form measurements.

Part no.	Adjustment range	Tilt	Load capacity	Weight	Platform area (W x L)	Dimensions (W x L x H)
112-5083	165 mm (6.5 in)	-	150 kg (331 lbs)	45 kg (99 lbs)	180 x 1280 mm (7.1 x 50.4 in)	370 x 1280 x 100 mm (14.6 x 50.4 x 3.9 in)
112-4806	140 mm (5.5 in)	-	100 kg (220 lbs)	45 kg (99 lbs)	180 x 900 mm (7.1 x 35.4 in)	350 x 900 x 107 mm (13.8 x 35.4 x 4.2 in)
112-4820	140 mm (5.5 in)	45°	30 kg (66 lbs)	45 kg (99 lbs)	180 x 800 mm (7.1 x 31.4 in)	350 x 800 x 190 mm (13.8 x 31.4 x 7.5 in)

## V blocks (standard, roller, adjustable and Multi)



**Standard / roller** - Matched pair of V block with for the positioning and support of large, cylindrical components.



**Adjustable** - Micrometer adjustment V block with position lock and T-slot mounting on the rear.

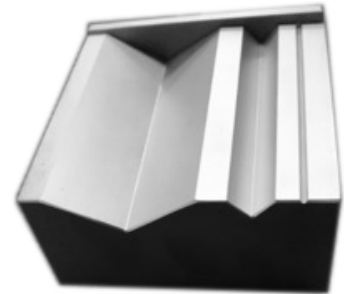

**Multi** - Component support with multiple V slots, intended for small lightweight components, comes with removable end stop plate and T-slot mounting on the rear.

Part no.	Adjustment range	V slot angle	Weight	Dimensions (W x L x H)
112-1645	-	120°	6 kg (13 lbs)	90 x 115 x 150 mm (3.5 x 4.5 x 5.9 in)
155-P60013	-	120°	6 kg (13 lbs)	90 x 130 x 135 mm (3.5 x 5.1 x 5.3 in)
112-1326	13 mm (0.5 in)	120°	2.5 kg (5.5 lbs)	85 x 90 x 40 mm (3.3 x 3.5 x 1.6 in)
112-5135	-	120° (Max Dia. Ø80 mm), 90° (Max Dia. Ø15 mm), 90° (Max Dia. Ø2 mm)	2.5 kg (5.5 lbs)	85 x 101 x 40 mm (3.3 x 4.0 x 1.6 in)

## Tee slot adaptor



Offsets the position of the rail slot 125 mm from the original position.

Part no.	Platform area
112-2032	120 x 100 mm (4.7 x 3.9 in)

## Levelling stage



Provides 3° tilting adjustment to bring workpiece parallel with the traverse unit.

Part no.	Platform area
112-3159	150 x 75 mm (5.9 x 2.95 in)

## Precision vice



High carbon steel construction with precision ground faces, 90 degree vee on clamping jaws. Squareness and parallelism 5 µm.

Other sizes available upon request.

Part no.	Range	Weight	Dimensions (W x L x H)
112-4931	65 mm (2.6 in)	3 kg (7 lbs)	50 x 155 x 55 mm (2.0 x 6.1 x 2.2 in)
112-4932	85 mm (3.3 in)	3.8 kg (8 lbs)	63 x 190 x 63 mm (2.5 x 7.5 x 2.5 in)
112-4933	100 mm (3.9 in)	5 kg (11 lbs)	73 x 210 x 70 mm (2.9 x 8.3 x 2.8 in)
112-4934	125 mm (4.9 in)	11 kg (24 lbs)	88 x 250 x 80 mm (3.5 x 9.8 x 3.1 in)
112-4935	160 mm (6.3 in)	19.5 kg (43 lbs)	125 x 300 x 100 mm (4.9 x 11.8 x 3.9 in)

## Ball joint (Precision vice, vice and precision chuck)



Provides universal positioning via 360° turn & rotation and 90° tilt; especially for lightweight or small components.

Part no.	Adjustment diameter	Internal range	External range	Rotation	Tilt	Weight	Dimensions (W x L x H)
112-4898	-	55 mm (2.2 in)	-	360°	90°	5 kg (11 lbs)	150 x 60 x 180 mm (5.9 x 2.4 x 7.1 in)
112-2695	-	228.6 mm (9 in)	-	360°	90°	Available on request	Available on request
112-4899	0-63 mm (0-2.5 in)	15-58 mm (0.6-2.3 in)	0.8-53 mm (0.03-2.1 in)	360°	90°	5 kg (11 lbs)	Ø120 x 172 mm

## Centre & levelling lens holder



Uses an aperture style mechanism for fast, repeatable centering of small components, predominantly used for use with small lenses

Part no.	Max. Work piece weight	Capacity (diameter)
112-3163	4.5 Kg (9.9 lbs)	10-75 mm (0.21-2.95 in)

## Optical glass flat



For checking the straightness and alignment of the gauge and traverse unit.

Clear aperture: 200 x 10 mm (7.9 x 0.4 in)  
Flatness:  $\lambda/10$  @ 633 Nm  
Parallelism: 0.01 mm

Part no.	Dimensions (W x L x H)
112-3401	220 x 35 x 50 mm (8.7 x 1.4 x 2.0 in)

## Lens riser



Holds part at optimum measurement height. Measuring close to the cresting height will improve the accuracy and reliability of the results. Concentric rings on the top face to provide quick centering of parts, kinematic location.

Part no.	Height
112-4169	80 mm Radius (3.15 in)

## Tilt & rotary stage for aspherics



Precision stage assembly with Y axis positioning 25 mm (1.0 in) travel and load capacity of 30 Kg (66 lbs). Rotary stage 125 mm (4.9 in) diameter with  $\pm 30$  arc minutes of manual levelling.

Part no.	Load capacity	Weight	Platform area
112-3402	30 Kg (66 lbs)	Available on request	125 mm (4.9 in)

## Right angled attachment



90° gauge attachment for inductive gauge to access features inaccessible by inline measurement.

Part no.	Type
112-4591	1 & 2 mm Inductive gauge
112-4540	5 mm Inductive gauge

## Ball and roller unit

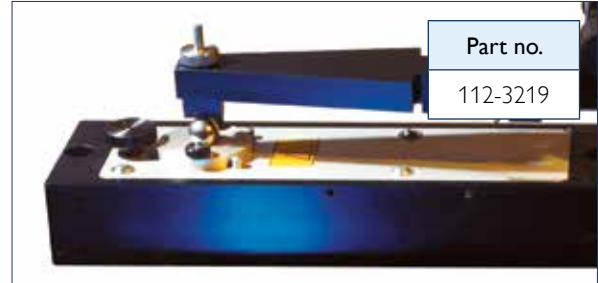

Special fixture for circumferential inspection of surface finish. Requires either 112-3247/112-3248 (see below).

Part no.	Plate type	Ball diameter
112-3247	Ball roller plates (set of 4)	1 - 25 mm (0.04 - 0.98 in)
112-3248	Cylindrical roller plates (set of 3)	1 - 16 mm (0.04 - 0.63 in)

## Wide range pick-up



Increase your system flexibility by changing to the interchangeable inductive wide range gauge to increase your gauge range to 28 mm and to fulfil your contour requirements. Includes one each of K501-1684, K501-1685 & K501-1686 wide range styli.

Part no.	Type
112-4592	Wide range pick-up
112-4909	Right angled wide range pick-up

## Video magnifier (inc. LCD monitor)

Video magnification option that enables small components to be viewed and set up for measurement.

The kit comprises camera, LCD screen, 12V DC power supplies and interconnecting cables.

Part no.	Fitting attachment
112-3741	Active AV frame
112-3846	Steel support frame

## Calibration ball (silicon nitride)



RONt Uncertainty 0.10  $\mu\text{m}$  (3.93  $\mu\text{in}$ ).

Part no.	Available sizes
112-4289	7.5 mm Radius (0.30 in)
112-2062	12.5 mm Radius (0.49 in)
112-1844	22 mm Radius (0.87 in)

## Calibration standard



Used for wide range gauge with range > 1 mm.  
Form accuracy 0.1  $\mu\text{m}$  over central 70°.  
Surface roughness 0.01  $\mu\text{m}$  @ 0.25 mm cut off.

Part no.	Available sizes
112-102057	49 mm Radius (1.93 in)
112-2028	80 mm Radius (3.15 in)
112-2734	110 mm Radius (4.33 in)

## Glass standard (single/double patch)



Other Ra values and step heights available on request.

Part no.	Available sizes
112-4304	0.3 $\mu\text{m}$ Ra
112-5505	0.8 $\mu\text{m}$ Ra
112-4303	1.6 $\mu\text{m}$ Ra
112-557	3 Line & Ra calibration (2.5 + 0.37 + 0.9 $\mu\text{m}$ )
112-964	3 Line & Ra calibration (2.5 + 0.37 + 0.024 $\mu\text{m}$ )

## Dual bias calibration standard



Top artefact for normal bias calibration  
Bottom artefact for reverse bias calibration  
Optimised radius uncertainty  
Includes a 4 mm ball for stylus tip to tip calibration

Part no.	Available sizes
112-103469	12.5 mm Radius (0.49 in)
112-103470	22 mm Radius (0.87 in)
112-103471	49 mm Radius (1.93 in)

## Work holding

Part no.	Form Talysurf® PGI NOVUS	Form Talysurf® PGI	Form Talysurf® i-Series/WRi	Form Talysurf® i-Series PRO	Form Talysurf® PGI Optics	Form Talysurf® PGI Matrix	Form Talysurf® PGI Freeform
112-3163	✓	✓	✓	✓	✓		
112-4091	✓	✓	✓	✓	✓		
112-1826	✓	✓	✓	✓	✓		
112-4923	✓	✓	✓	✓	✓		
112-3067	✓	✓	✓	✓	✓		
112-4902	✓	✓	✓	✓	✓		
112-3064	✓	✓	✓	✓	✓		
112-102576	✓			✓			
112-102577	✓			✓			
112-102578	✓			✓			
112-102579	✓			✓			
112-102580	✓			✓			
112-102581	✓			✓			
112-5342		✓	✓		✓		
112-5353		✓	✓		✓		
112-5347		✓	✓		✓		
112-5422		✓	✓		✓		
112-5343		✓	✓		✓		
112-5429		✓	✓		✓		
112-5083							
112-4806							
112-4820							
112-1645	✓	✓	✓	✓	✓		
155-P60013	✓	✓	✓	✓	✓		
112-1326	✓	✓	✓	✓	✓		
112-5153	✓	✓	✓	✓	✓		
112-2032	✓	✓	✓	✓	✓		
112-3159	✓	✓	✓	✓	✓		
112-4931	✓	✓	✓	✓	✓	✓	✓
112-4932	✓	✓	✓	✓	✓	✓	✓
112-4933	✓	✓	✓	✓	✓	✓	✓
112-4934	✓	✓	✓	✓	✓	✓	✓
112-4935	✓	✓	✓	✓	✓	✓	✓
112-4898	✓	✓	✓	✓	✓		
112-2695	✓	✓	✓	✓	✓		
112-4899	✓	✓	✓	✓	✓		

# Form Talysurf®

Part no.	Form Talysurf® PGI NOVUS	Form Talysurf® PGI	Form Talysurf® i-Series /WRi	Form Talysurf® i-Series PRO	Form Talysurf® PGI Optics	Form Talysurf® PGI Matrix	Form Talysurf® PGI Freeform
112-3163					✓	✓	✓
112-3401	✓	✓	✓	✓	✓	✓	✓
112-4169					✓	✓	✓
112-3402					✓		
112-4591			✓	✓			
112-4540			✓	✓			
112-4592			✓	✓			
112-4909			✓	✓			
112-3219			✓	✓			
112-3741	✓	✓	✓	✓	✓	✓	✓
112-3846	✓	✓	✓	✓	✓		

## Calibration

Part no.	Form Talysurf® PGI NOVUS	Form Talysurf® PGI	Form Talysurf® i-Series /WRi	Form Talysurf® i-Series PRO	Form Talysurf® PGI Optics	Form Talysurf® PGI Matrix	Form Talysurf® PGI Freeform
112-4289	✓	✓	✓	✓	✓	✓	✓
112-2062	✓	✓	✓	✓	✓	✓	✓
112-1844	✓	✓	✓	✓	✓	✓	✓
112-102057	✓	✓	✓	✓	✓	✓	✓
112-2028	✓	✓	✓	✓	✓	✓	✓
112-2734	✓	✓	✓	✓	✓	✓	✓
112-4304	✓	✓	✓	✓	✓	✓	✓
112-5505	✓	✓	✓	✓	✓	✓	✓
112-4303	✓	✓	✓	✓	✓	✓	✓
112-557	✓	✓	✓	✓	✓	✓	✓
112-964	✓	✓	✓	✓	✓	✓	✓
112-103469	✓						
112-103470	✓						
112- 103471	✓						



## Precision six jaw component chuck



Precision six jaw component chuck. Self centring with removable jaws, can be used internally or externally. Mounts kinematically onto the table top.

Part no.	Capacity (inside diameter)	Capacity (outside diameter)
112-1859	20-90 mm (0.78-3.54 in)	2-32 mm (0.08-1.26 in)

## Centring attachment



For fast, repeatable centring of small components up to 4.5 Kg (9.9 lbs).

Part no.	Capacity (diameter)
112-2691	5.4 - 151 mm (0.21 - 5.95 in)

## Precision collet chuck



Part no.	Type	For use with
112-3662	Removable	Manual or automated tables
112-3549	Fixed	Automated tables

Precision collet chuck with interchangeable collets (not included). Please select collet from the list below.

Part no.	Size of collet
112-3554-1.0	1.0 mm
112-3554-1.5	1.5 mm
112-3554-2.0	2.0 mm
112-3554-2.5	2.5 mm
112-3554-3.0	3.0 mm

Part no.	Size of collet
112-3554-3.5	3.5 mm
112-3554-4.0	4.0 mm
112-3554-4.5	4.5 mm
112-3554-5.0	5.0 mm
112-3554-5.5	5.5 mm

Part no.	Size of collet
112-3554-6.0	6.0 mm
112-3554-6.5	6.5 mm
112-3554-7.0	7.0 mm
112-3554-7.5	7.5 mm
112-3554-8.0	8.0 mm

## Three jaw component chuck



Three jaw component chuck. Self-centring with reversed jaws, can be used internally or externally. Mounts kinematically onto the table top.

Part no.	Weight	Base plate diameter	Capacity (inside diameter)	Capacity (outside diameter)
112-4852	3 kg (6.6 lbs)	120 mm (4.72 in)	23 - 65 mm (0.91 - 2.56 in)	0.8 - 68 mm (0.03 - 2.68 in)
112-4853	5 kg (11 lbs)	145 mm (5.71 in)	31 - 85 mm (1.22 - 3.35 in)	1 - 90 mm (0.04 - 3.54 in)
112-4854	9 kg (20 lbs)	170 mm (6.69 in)	36 - 110 mm (1.42 - 4.33 in)	1 - 115 mm (0.04 - 4.53 in)

## Three jaw component chuck with baseplate and handles



Three jaw component chuck. Self-centring with reversed jaws, can be used internally or externally.

Baseplate fitted with handles that mounts kinematically onto the table top (112-4855, 4856).

Base plate with handles mounts into the Talyrond® 450 T-slot (112-4857, 4858, 4859).

Part no.	Weight	Base plate diameter	Base plate dimensions	Capacity (inside diameter)	Capacity (outside diameter)
112-4855	3 kg (6.6 lbs)	265 mm (10.43 in)	-	43 - 130 mm (1.69 - 5.12 in)	1.5 - 140 mm (0.063 - 5.51 in)
112-4856	5 kg (11 lbs)	295 mm (11.61 in)	-	52 - 190 mm (2.05 - 7.48 in)	1.5 - 200 mm (0.06 - 7.87 in)
112-4857*	10 kg (22 lbs)	-	260 x 210 mm (10.24 x 8.27 in)	36 - 110 mm (1.42 - 4.33 in)	1 - 115 mm (0.04 - 4.53 in)
112-4858*	15 kg (33 lbs)	-	260 x 210 mm (10.24 x 8.27 in)	43 - 130 mm (1.69 - 5.12 in)	1.5 - 140 mm (0.063 - 5.51 in)
112-4859*	20 kg (44 lbs)	-	310 x 260 mm (12.20 x 10.24 in)	52 - 180 mm (2.05 - 7.09 in)	1.5 - 190 mm (0.06 - 7.48 in)

## Digital crankshaft fixture

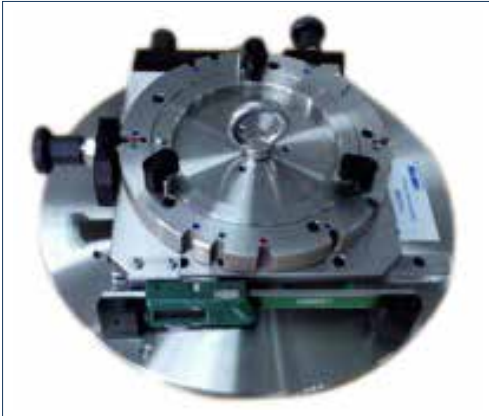

The crankshaft fixtures are designed to orientate a crankshaft to enable access to features and allows measurements to be taken using a Talyrond® 565H. The fixture consists of a main base plate that attaches to the Talyrond® worktable. A top carriage that slides relative to the base plate to obtain the required throw for measuring the pin bearings. A rotating stage that allows the crankshaft to be correctly positioned to the required orientation allowing all pins to be measured.

The fixture is fitted with a Digital Vernier Calliper to enable the component to be moved accurately between main and pin bearing measurements.

The fixture can also be supplied with interchangeable timing gates, each dedicated to a single component throw. The timing gate sets the linear movement of the fixture to the distance between the main and pin bearings.

### Locating the crankshafts on the fixture

The components need to be securely clamped in place to enable safe operation of the fixture. To this end the fixture can be supplied with dedicated adaptor plates, or with a chuck adaptor assembly.

#### Option 1: Adaptor Plates

An adaptor plate is supplied fully machined for each individual component. It is bolted to the component which can then be clamped safely and securely onto the fixture. The adaptor plate ensures the correct radial orientation of the component (with a pin bearing in line with the linear stage movement axis).

#### Option 2: Universal Crankshaft Fixture Chuck

The assembly would consist of a three Jaw chuck with 90 mm diameter capacity mounted on an adaptor plate to enable it to be used with a universal crankshaft fixture. This chuck assembly can be fitted with a removable orientation block (designed for a single component type) to ensure correct alignment to the fixture's linear movement axis. If this option is not taken the operator must visually align the component so that the pin journal axis is in line with the main bearing axis and the linear slide axis.



Part no.	Weight	Load capacity	Angular positions	Offset throw range	Overall dimensions
112-5458	11 kg (6.6 lbs)	35 kg (6.6 lbs)	60°, 75°, 90°	0 - 65 mm (0 - 2.56 in)	Ø 300 x H 85 mm (11.81 x 3.35 in)

### Associated accessories

Part no.	Description
155-P61606*	Digital Crankshaft Fixture with a single Component adaptor. Consists of Digital Crankshaft Fixture and an adaptor modified to suit a single customer component.
155-P60367	Chuck with baseplate for location on the Digital Crankshaft Fixture. Clamping range 1-90 mm (Outer Diameter), 31-85 mm (Inner Diameter), 2,2 Kg (2.2Kg).
155-P54108**	Gauge Extension Arm Assembly (supplied with 155-P54248 Stylus).
155-P54248	150 mm Effective Length, 2.0 mm Diameter Ball Stylus for 155-P54108
155-P61558**	Gauge Extension Arm Assembly (supplied with 155-P102908 Stylus).
105-102908	160 mm Effective Length, 2.0 mm Ball Ended Stylus

\* Part drawing required with order.

\*\* For manual gauge orientation systems only.

## Talymin 6 gauge extension arm\*



The gauge extension arm is used to access small diameters on components with a large swing radius, for example to access the pin bearing on a crankshaft whilst avoiding the counterweight. A 150 mm stylus is included with the assembly.

Please note, the column on the instrument may need to be set to its rear position to accommodate the gauge extension arm (using moulding insert 112-2871). Please refer to the applications department with component drawings and measurement requirements for confirmation.

Part no.	Effective length	Stylus included
155-P54108	240 mm (9.45 in)	155-P54248 (150 mm)
155-P61558	160 mm (6.30 in)	155-102908 (160 mm)

## Talymin 6 carbon fibre drop arm\*



The Talyrond® 565H drop arm is used to enable access deep inside components, for example into bores on automotive components.

Please note that the drop arm length is calculated from the gauge connection to the tip of the stylus (100 mm length stylus not included). The extension value is the extra length gained over and above the standard. Minimum bore size to be accessed for measurement is 30 mm.

Part no.	Length
155-P59771-240	240 mm (9.45 in)
155-P59771-500	500 mm (19.69 in)
155-P59771-750	750 mm (29.53 in)

## Talymin 4 carbon fibre drop arm



The Talyrond® 450 drop arm is used to enable access deep inside components, for example into cylinder, crankshaft and camshaft bores.

Please note that the drop arm length is calculated from the gauge connection to the tip of the stylus (100 mm length stylus not included). The extension value is the extra length gained over and above the standard. The Talymin 4 gauge has a diameter of 23.5 mm. Minimum bore size for practical use is therefore 26 mm. For smaller diameters refer to the small bore drop arm.

Part no.	Length
155-P53236-240	240 mm (9.45 in)
155-P53236-350	350 mm (13.78 in)
155-P53236-500	500 mm (19.69 in)
155-P53236-750	700 mm (27.56 in)

## Talyrond® 450 Crankshaft arm



A crankshaft arm offsets the gauge position to clear the swing radius created by the counterweights when measuring the pin or main journals. An extended stylus, also supplied, enables access to the required measurement positions (Includes stylus).

Part no.	Length	Stylus included
155-P54760-572	572 mm (22.52 in)	155-P30358
155-P54760-602	602 mm (23.70 in)	155-P30358
155-P54760-660	660 mm (25.98 in)	155-P30358
155-P54760-750	750 mm (29.53 in)	155-P30358
155-P54760-1000	1000 mm (39.37 in)	155-P37074

## Small bore drop arm



Small bore drop arms are used to enable measurement access deep inside components where the standard drop arms are too large. The small bore drop arm has a built in gauge and can be used in bores down to 21 mm in diameter.

Please note the drop arm length is the length from the gauge connection to tip of the stylus (100 mm length stylus). The extension value is the extra length gained over and above the standard (Includes small bore gauge and stylus).

Part no.	Length
155-P54763-500	500 mm (19.69 in)
155-P54763-750	750 mm (29.53 in)

## Multi-part measurement - Rotary stage



Complete automation of multi-part measurement, provides cost effective, high volume throughput.

The optional rotary stage transforms the Talyrond® 500 into a multi-part measurement system. This portable device simply sits on the spindle table via three point location and plugs into a concealed socket.

The rotary stage has a unique counterbalanced design ensuring measurement without any loss of accuracy. Simple control is provided via our Ultra software interface, enabling complete automated measurement of up to 20 parts. This makes the Talyrond® 500 ideal for the measurement of small components in the bearings, optics, medical and automotive industries.

Part no.	Weight	Table top diameter	Maximum speed	Rotational accuracy	Repeatability	Axial error motion	Maximum load axial*	Tilt error	Pitch circle diameter (PCD)**
112-103338	7 kg (15 lbs)	150 mm (5.9 in)	20 rpm	80 arc seconds	5 arc seconds	5 µm	5 kg (11 lbs)	10 arc seconds	129.7 mm

## Ultra high precision roundness - Indexing stage



The most accurate roundness measurement in the world. Taylor Hobson's UHPR indexing stage provides unrivalled repeatability and accuracy for roundness measurements.

The stage makes the Talyrond® ideal for measuring components such as bearings, cylinders, calibration artefacts and much more...

Part no.	Weight	Table top diameter	Maximum speed	Rotational accuracy	Repeatability	Radial error motion	Maximum load axial
112-100214	7 kg (15 lbs)	150 mm (5.9 in)	20 rpm	80 arc seconds	5 arc seconds	5 µm	20 kg (44 lbs)

\* Greater weights can be accommodated, please contact Taylor Hobson.

\*\* Alternative PCD available on request.

## Test cylinder (Precision/High precision)



For verification of the instrument's vertical straightness accuracy and parallelism of the vertical axis to the spindle axis.

Straightness over central 90 % of test cylinder.

Part no.	Length	Roundness	Straightness*
112-1888	300 mm (11.81 in)	<0.25 µm (9.84 µin)	<0.50 µm (19.69 µin)
112-1997	500 mm (19.68 in)	<0.25 µm (9.84 µin)	<0.50 µm (19.69 µin)
112-3604	1000 mm (39.37 in)	<0.75 µm (29.53 µin)	<3.00 µm (118.11 µin)
112-3670	100 mm (3.93 in)	<0.2 µm (7.87 µin)	<0.2 µm (7.87 µin)

## Ball standard



Talyrond® ball calibration standard. Required for use with contour or form software, this calibration standard corrects for the arcuate motion of the stylus.

Part no.	Radius	Gauge compatibility**
112-4305	7.5 mm (0.29 in)	2 mm
112-4319	12.5 mm (0.49 in)	2 mm
112-4092	22.5 mm (0.89 in)	2 mm / 4 mm
Optional UKAS and METAS calibration certificates available		
UKAS	Roundness uncertainty	0.05 µm (1.97 µin)
UKAS	Diameter uncertainty	0.5 µm (19.69 µin)
METAS	Roundness uncertainty	0.04 µm (1.57 µin)
METAS	Diameter uncertainty	0.05 µm (1.97 µin)

## Flick standard



For rapid calibration of the gauge head, alternative to the standard gauge calibration set.

Part no.	Available sizes
112-2308	20 µm (788 µin)
112-2233	300 µm (0.012 in)

## Roughness standard



Calibration standard for circumferential and vertical roughness. Traceable international standards.

Part no.	Vertical	Circumferential
112-4341	Ra 0.35 µm (13.78 µin) Rz 1 µm (39.37 µin)	Ra 0.35 µm (13.78 µin) Rz 1 µm (39.37 µin)

\* Straightness over central 90% of test cylinder.

\*\* Based on the use of a 90° diamond conisphere stylus. If using smaller or larger cone angles please consult Taylor Hobson to confirm compatibility.

Note: Optional UKAS calibration certificate available on calibration artefacts.

## Calibration set



For calibrating the gauge head. The set comprises a circular glass flat and four gauge blocks, (Ø 50 mm, 2.5 mm, 2.8 mm, 2.96 mm, 3.0 mm)

**Part no.**

112-2889

## Glass hemisphere standard



For checking total system performance.

**Part no.**

112-436

**Roundness**

< 0.05 µm (2 µin)

112-2324

< 0.01 µm (0.4 µin)

## Force setting gauge



Used to verify stylus force, to prevent scoring and ringing on delicate parts. For use with surface and 3D option.

**Part no.**

112-3808

## Cresting standard



For checking the vertical and horizontal alignment of the gauge head.

**Part no.**

112-1876

## Horizontal straightness standard



For checking the straightness and alignment of the horizontal arm with respect to the spindle axis.

**Part no.**

112-1998

**Available sizes**

Ø 250 mm (10 in) Flatness ( $\lambda/10$  @ 633 Nm)

112-2334

Ø 350 mm (13.7 in) Flatness ( $\lambda/4$  @ 633 Nm)



## Work holding

Part no.	Talyrond® 465H/485H	Talyrond® 565H/585H	Talyrond® 595H	Talyrond® 565/585 HS	Talyrond® 595 HS	Talyrond® 565/585 XL	Talyrond® 1700	Talyrond® 2000	Talyrond® 450
112-1859	✓	✓	✓	✓	✓	✓	✓	✓	
112-2691		✓	✓	✓	✓	✓	✓	✓	
112-3662	✓	✓	✓	✓	✓	✓	✓	✓	
112-3549		✓	✓	✓	✓	✓	✓	✓	
112-4852	✓	✓	✓	✓	✓	✓	✓	✓	
112-4853	✓	✓	✓	✓	✓	✓	✓	✓	
112-4854	✓	✓	✓	✓	✓	✓	✓	✓	
112-4855	✓	✓	✓	✓	✓	✓	✓	✓	
112-4856	✓	✓	✓	✓	✓	✓	✓	✓	
112-4857									✓
112-4858									✓
112-4859									✓
112-5458		✓	✓	✓	✓	✓	✓	✓	
155-P54108		✓	✓	✓	✓	✓			
155-P61558		✓							
155-P59771		✓	✓	✓	✓	✓			
155-P53236									✓
155-P54760									✓
155-P54763									✓
112-103338				✓	✓				
112-100214			✓		✓				

## Calibration

Part no.	Talyron® 465H/485H	Talyron® 565H/585H	Talyron® 595H	Talyron® 565/585 HS	Talyron® 595 HS	Talyron® 565/585 XL	Talyron® 1700	Talyron® 2000	Talyron® 450
112-1888	✓	✓	✓	✓	✓	✓	✓	✓	✓
112-1997	✓	✓	✓	✓	✓	✓	✓	✓	✓
112-3604	✓	✓	✓	✓	✓	✓	✓	✓	✓
112-3670	✓	✓	✓	✓	✓	✓			
112-4305	✓	✓	✓	✓	✓	✓	✓	✓	
112-4319	✓	✓	✓	✓	✓	✓	✓	✓	
112-4092	✓	✓	✓	✓	✓	✓	✓	✓	
112-2308	✓	✓	✓	✓	✓	✓	✓	✓	✓
112-2233	✓	✓	✓	✓	✓	✓	✓	✓	✓
112-4341	✓	✓	✓	✓	✓	✓			
112-2889	✓	✓	✓	✓	✓	✓	✓	✓	✓
112-436	✓	✓	✓	✓	✓	✓	✓	✓	✓
112-2324			✓		✓				
112-3808	✓	✓	✓	✓	✓	✓	✓	✓	
112-1876	✓	✓	✓	✓	✓	✓	✓	✓	✓
112-1998	✓	✓	✓	✓	✓	✓	✓	✓	✓
112-2334									✓

## 3-jaw clamping chuck

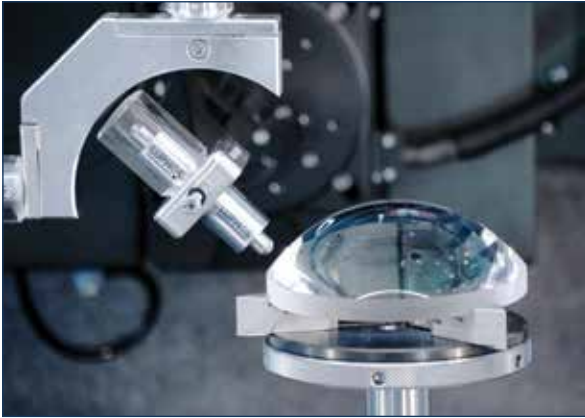

Ideal for mounting parts on the LUPHOScan. Giving objects a stable support is important in order to achieve high accuracy. 3-jaw-clamping chucks provide great flexibility as each chuck covers a big range of diameters that can be mounted.

Part no.	Shaft diameter (Expansion)	Weight	Capacity (inside diameter)
112-5046	25 mm (0.98 in)	0.6 kg (1.3 lbs)	22 - 61 mm (0.87 - 2.40 in)
112-5047	25 mm (0.98 in)	1.1 kg (2.4 lbs)	27 - 99.5 mm (1.06 - 3.92 in)
112-5048	25 mm (0.98 in)	2.5 kg (5.5 lbs)	52 - 141 mm (2.05 - 5.55 in)
112-5049	25 mm (0.98 in)	Available on request	1 - 185 mm (0.04 - 7.28 in)
112-5050	40 mm (1.57 in)	Available on request	27 - 99.5 mm (1.06 - 3.92 in)
112-5051	40 mm (1.57 in)	Available on request	52 - 141 mm (2.05 - 5.55 in)
112-5052	40 mm (1.57 in)	Available on request	1 - 185 mm (0.04 - 7.28 in)

## Centre & levelling table

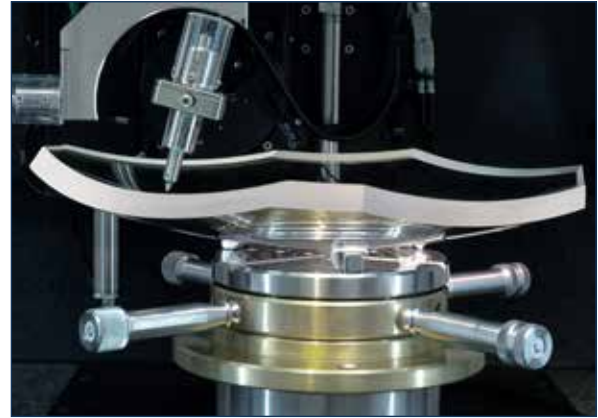

Ideal for aligning parts on the LUPHOScan. Centring and levelling objects correctly in the platform is important in order to achieve high accuracy (primarily for aspheres).

- Manual centering range:  $\pm 1.25$  mm ( $\pm 0.054$  in)
- Manual levelling range :  $\pm 30$  arc minutes

Part no.	Shaft diameter (Expansion)	Weight	Table top diameter
112-5030	25 mm (0.98 in)	6 kg (13.2 lbs)	Ø 125 mm (4.92 in)
112-5032	25 mm (0.98 in)	Available on request	Ø 200 mm (7.87 in)
112-5033	40 mm (1.57 in)	Available on request	Ø 125 mm (4.92 in)
112-5034	40 mm (1.57 in)	Available on request	Ø 200 mm (7.87 in)
112-5035	40 mm (1.57 in)	Available on request	Ø 350 mm (13.78 in)

## Calibration cylinder



Precision cylinder made of steel for the cylindrical calibration of LUPHOScan HD systems. The cylinders come with a shaft to use them directly with the LUPHOScan.

This calibration is important to accurately measure steep parts because it compensates a certain tilt of the vertical reference mirror.

Part no.	Shaft diameter (Expansion)
112-5459	25 mm (0.98 in)
112-5548	40 mm (1.57 in)

## Calibration flat



Calibration flat made of glass for the plane calibration of LUPHOScan systems.

This calibration is important to accurately know how the object probe is positioned with regard to the centre of rotation of the spindle. It also checks for changes in the spindle movement and compensates a certain tilt of the horizontal reference mirror.

Part no.	Shaft diameter (Expansion)
112-5432	25 mm (0.98 in)
112-5509	40 mm (1.57 in)

## Calibration balls\*



Certificated calibration ball with RoC of 12.5 mm for spherical calibration. The ball is mounted to use it directly with the LUPHOScan systems.

This calibration is important to know exact dimensions of the object probe, check for changes in the spindle movement and correct the shape of the cylindrical reference mirror.

Part no.	Shaft diameter (Expansion)	Certification
112-5433UC	25 mm (0.98 in)	UKAS
112-5433MT	25 mm (0.98 in)	METAS
112-5510UC	40 mm (1.57 in)	UKAS
112-5510MT	40 mm (1.57 in)	METAS

## Clamping sleeve



Adaptor to reduce a 40 mm hydraulic expansion chuck to 25 mm. With this adaptor one is more flexible as one hydraulic expansion chuck on the platform can be used for two types of shafts.

Part no.	Shaft diameter (Expansion)
112-5285	25 mm (0.98 in)

## Transit case (Calibration standards)

Transit case for the plane and spherical reference calibration standards.

Part no.	Product
48-1034	LUPHOScan 260
48-1033	LUPHOScan 420

## Probes



Various object probes suiting different applications. For certain kind of objects like Fresnel lenses, non-rotational symmetric lenses or small concave lenses it makes sense to use a special object probe.

Please contact Taylor Hobson to discuss the slight disadvantages each probe may have if used for applications other than the ones they are designed for.

Example probe dimensions illustrated below.

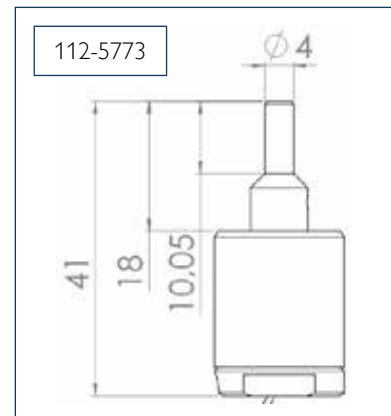
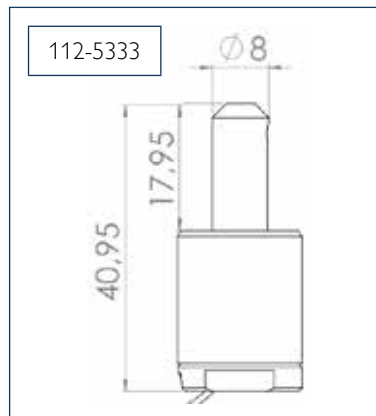
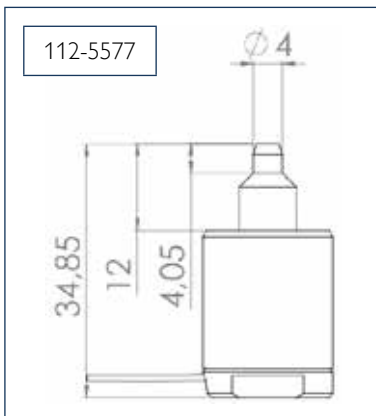

Part no.	Probe type
112-5577	Object probe for Fresnel lenses (slope on Fresnels up to 55°; aspheres still 90°)
112-5533	HNA probe for non-rotational symmetric objects (tangential slopes up to ± 9°)
112-5333	Object probe with 10 mm elongation (8 mm tip diameter)
112-5773	Object probe with long tube optics and 10 mm elongation (4 mm tip diameter)
112-5808	Object probe with long tube optics and 8 mm elongation (4 mm tip diameter)

## LUPHOSwap\*

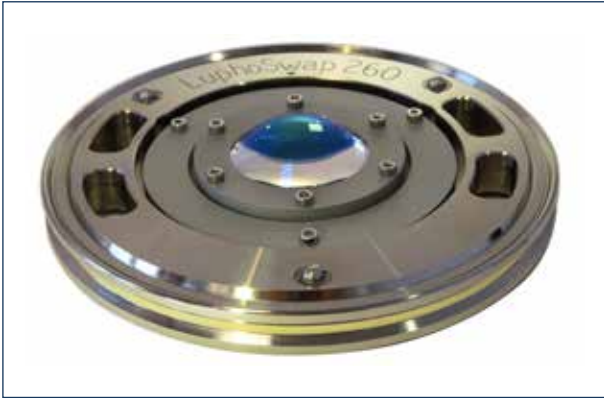

Extension to enable measurement of wedge error; decentre error and thickness of lenses with LUPHOScan systems. The hardware can only be used when the matching software module is purchased.

The tool comprises a sophisticated fixture, a calibrated reference ring and a software module. After measuring the form of the first side and its positioning with regard to the reference surfaces, the operator turns over the ring together with the lens and the system automatically measures the second side with regard to the reference surfaces.

Due to the absolute measurement capability of the probes employed, the results from both sides can be correlated in order to determine the exact lens thickness of the part, the wedge and decentre errors of the two surfaces and their rotational orientation.

Part no.	Type	Shaft diameter (Expansion)	Max. lens diameter
112-5150	LUPHOSwap fixture, 1 reference ring and software (Interalignment module)	25 mm (0.98 in)	75 mm (2.95 in)
112-5165	LUPHOSwap fixture and 1 reference ring (requires software)	25 mm (0.98 in)	75 mm (2.95 in)
K510-3534	LUPHOSwap reference ring	25 mm (0.98 in)	75 mm (2.95 in)

## Precision six jaw component chuck

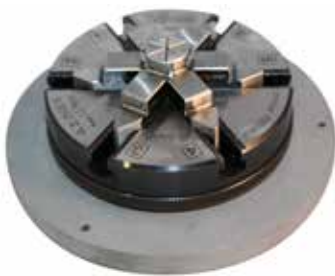

Precision six jaw component chuck. Self centring with removable jaws, can be used internally or externally. Mounts kinematically onto the table top.

Part no.	Capacity (inside diameter)	Capacity (outside diameter)
112-1859	20-90 mm (0.78-3.54 in)	2-32 mm (0.08-1.26 in)

## LUPHOStation

High desk with PC mount, Space-saving workstation for the LUPHOScan.

The LUPHOStation can hold the complete PC with peripherals and has some extra shelf space.

Perfect for manufacturing department where users only stay at the platform for a short time.

Part no.	Dimensions (W x L x H)
112-5300	800 x 630 x 1100 mm (31.5 x 24.8 x 43.3 in)

### Y-axis stages (standard or with V assembly)



Precision stage assembly with Y-axis positioning, mounting holes or V block for component fixturing.

Includes location plate for mounting on granite base.

Part no.	Adjustment range	For use with	Load capacity	Weight	Platform area (W x L)	Vee plate size (W x L)	Dimensions (W x L x H)
112-3163	25 mm (1.0 in)	T-slots	30 kg (66 lbs)	1.9 kg (4 lbs)	120 x 120 mm (4.7 x 4.7 in)	-	218 x 180 x 40 mm (8.6 x 7.1 x 1.6 in)
112-3067	25 mm (1.0 in)	-	25 kg (55 lbs)	2.4 kg (5 lbs)	-	90 x 90 mm (3.5 x 3.5 in)	140 x 180 x 80 mm (5.5 x 7.1 x 3.1 in)

### Ball and roller unit (Intra)



Special fixture for circumferential inspection of surface finish. Requires either 112-3247/112-3248 (see below).

Part no.	Plate type	Ball diameter
112-3247	Ball roller plates (set of 4)	1 - 25 mm (0.04 - 0.98 in)
112-3248	Cylindrical roller plates (set of 3)	1 - 16 mm (0.04 - 0.63 in)

### Base frame & granite

Metal base frame with granite table top, winged work surfaces for All-in-one PC and parts. Designed for use with Intra or Surtronic® Roundness systems.

Optional environmental enclosure available.



Part no.	Dimensions (W x L x H)
112-5084	1470 x 520 x 800 mm (57.9 x 20.5 x 31.5 in)

### Wide range pick-up\* (Intra)



The wide range gauge provides up to 32 mm (1.26 in) of range with 15 nm (4.8 µin) resolution. Suitable for form and contour measurements.

\* Requires TalyProfile Contour software.

## Deep bore extension rods



Provides extension to pick-up for measurements into deep holes. Place between pick-up cable and pick-up.

Part no.	Extension	Reach	Product
112-1533	100 mm (3.9 in)	160 mm (6.3 in)	Surtronic® S-100 Series
112-1510	200 mm (7.8 in)	260 mm (10.2 in)	

## Hard flight/carry case



Air and water tight case that provides the product with extra protection for safe storage and/or transportation.

Part no.	Product
112-5003	Surtronic® Duo
112-5002	Surtronic® S-100 Series

## Magnetic base



Lightweight compact base specially designed to allow for measurements in multiple orientations including upside down on metallic surfaces.

Part no.	Product
112-4981	Surtronic® Duo

## Portable stand



Portable and light-weight stand enables access to multiple features on large parts.

Part no.	Product
112-5354	Surtronic® S-100 Series

## Flight case



Air and water tight case that provides the product with extra protection for safe storage and/or transportation.

Part no.	Product
117-270	Intra Touch / Contour

## Uninterruptible power supply



This UPM delivers clean, fully conditioned power which is free from noise, voltage spikes and common-mode disturbances.

Part no.	Input	Output
112-5752	230V, 50/60Hz, 2.7A	230V, 1.65A, 378W
112-5760	110V, 60Hz, 5.18A	120V, 3.15A, 378W



## Patented RapidCentre™ attachment

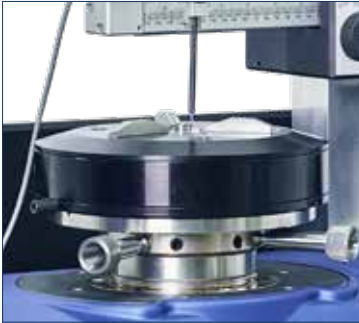

RapidCentre™ avoids valuable cycle time being lost on manual part centring. On most parts precision results are achieved following a very simple and fast loading procedure.

Now roundness measurements can be made in less than 30 seconds including part loading, centring, measurement, analysis and results display.

Designed for use with Surtronic® Roundness systems or Talyrond® R-170 Raceway.

Part no.	Max diameter	Inside diameter (Long jaws)	Outside diameter (Long jaws)	Inside diameter (Short jaws)	Outside diameter (Short jaws)
112-4313	200 mm (7.8 in)	-	-	65 - 160 mm (2.56 - 6.30 in)	3 - 115 mm (0.12 - 4.53 in)
112-4336	300 mm (11.7 in)	115 - 220 mm (4.53 - 8.67 in)	3 - 115 mm (0.12 - 4.53 in)	65 - 175 mm (2.56 - 6.89 in)	3 - 115 mm (0.12 - 4.53 in)

## Large table-top

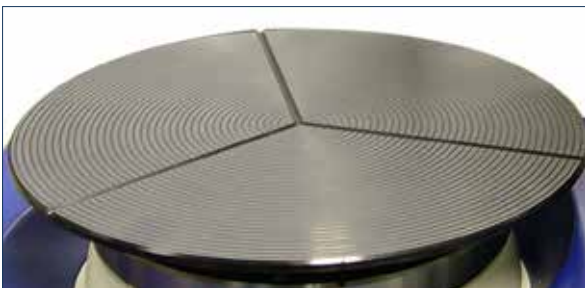

The large table-top allows Surtronic® Roundness systems to measure components with large diameters.

Part no.	Diameter
112-4314	300 mm (11.7 in)

## Adjustable crutch stop



Provides an adjustable crutch stop for crutch angle in order to return the stylus to a repeatable angle without having to re-calibrate.

Part no.	Product
112-5511	Surtronic® R-100 Series

## Vacuum chuck

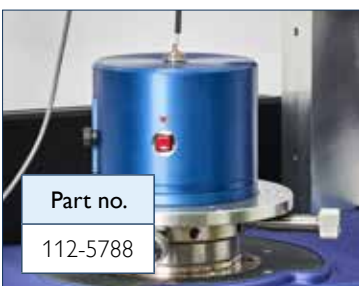

Part no.  
112-5788

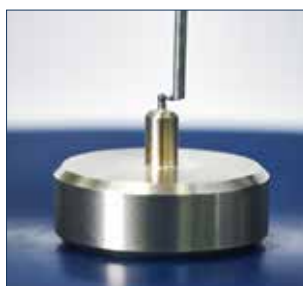

Battery operated vacuum chuck for Surtronic® Roundness systems or Talyrond® R-170 Raceway.

Ball holder is required (see below).

Part no.	Ball Diameter
112-5789	1 - 10 mm (0.039 - 0.39 in)
112-5790	10 - 30 mm (0.39 - 1.18 in)

## Spindle protection system (Surtronic® Roundness)

### Free standing advanced filter with air dryer unit

Air bearing spindles are extremely accurate and require clean and dry air to work effectively. The spindle protection system adds another level of filtration, preventing poor air supplies from contaminating spindles with oil, water and debris.

The spindle protection system has a 7 stage process to protect your instrument. The visual alarm warns of air supply issues before damage occurs.

System features include:

- Isolator switch
- Particle filters (5 µm, 0.3 µm and 0.01 µm)
- Dryer filter (Dew point -15°C)
- Pressure switch
- Visual alarm.



**Part no.**  
112-5000

## Vibration Isolation - Active AV120



Fully active isolation in seconds. Compensates vibration amplitudes of up to 500 µm/s. Vibration isolating feet.

Part no.	Dimensions
112-4495	500 x 400 x 90 mm (19.7 x 15.7 x 3.5 in)

## Column and stand



Granite base (400 x 250 mm) with manually operated column providing adjustment height of 260 mm.

Part no.	Product
112-2693	Surtronic® S-100 Series

### Glass hemisphere standard



For checking total system performance.

Part no.	Roundness
112-436	< 0.05 µm (2 µin)

### Flick standard



For rapid calibration of the gauge head, alternative to the standard gauge calibration set.

Part no.	Roundness
112-2233	300 µm (0.012 in)

### Calibration ball



Glass or silicon nitride standards for calibrating Intra systems.

Part no.	Available sizes
112-2062	12.5 mm Radius (0.49 in)
112-1844	22.5 mm Radius (0.89 in)
112-5417	38.76 mm Radius (1.53 in)

### Glass standard (single/double patch)



Other Ra values and step heights available on request.

Part no.	Available sizes
112-4304	0.3 µm Ra
112-4303	1.6 µm Ra
112-557	3 Line & Ra calibration (2.5 + 0.37 + 0.9 µm)

### Calibration standard

UKAS calibrated patch for calibrating Surtronic® S-100 or Surtronic® Duo



Part no.	Surface finish	Product
112-2937	5.8 µm Ra (229 µin)	Surtronic® Duo
112-1534	6.0 µm Ra (236 µin)	Surtronic® S-100 Series

### Optical glass flat

Used to check the straightness of a system. This standard can be used with our surface roughness instruments.



Part no.	Product
112-5537	Intra Touch / Contour

# Alignment & level

## Adjustable base



The basic adjustable base can be set to the appropriate step interval length up to 200 mm (8 in) for flatness measurement by the “Grid” or “Union Jack” method and for straightness measurement. It provides a base for the Talyvel® 6 Level Unit with self aligning seating pads adjustable to a graduated scale.

This accessory is invaluable for setting different interval lengths when carrying out flatness checks on granite and iron surface tables. This base can also be used for mounting an autocollimator reflector, used with side feet (112-1947 or 112-5827).

The adjustable bases is above, with tilt adjustment provided for setting the level unit to absolute horizontal.

Part no.	Step interval	Tilt
112-5826	200 mm (7.8 in)	-
112-2316	200 mm (7.8 in)	3°

## Block base



Part no.  
112-2314

This 300 mm (12 in) long base allows the Level Unit to be positioned along cylindrical objects (e.g. for the measurement of mill rolls and shafting).

The block base has 120° vee bearing faces, all bearing faces are ground to a flatness within 2.5 µm (100 µin).

## Stride base



Part no.  
112-2315

This accessory allows Talyvel® 6 or a bubble level to be mounted on the Taylor Hobson Micro Alignment Telescope to establish a truly horizontal line of sight.

## Right angled base/box frame

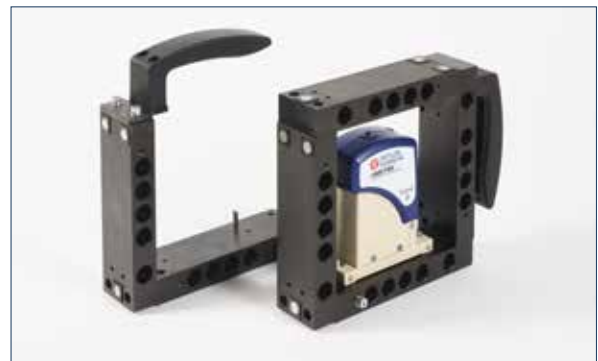

Measurement of vertical surfaces is facilitated by this simplified version of the box frame which has the advantage of being much lighter.

All bearing faces are ground to a flatness within 2.5 µm (100 µin) and adjacent faces are square to within 10 seconds of arc (0.05 mm/metre (50 µin/in)).

The box frame is useful for checking inverted or vertical surfaces.

Part no.	Product
112-4583	Right angled base (Left)
112-2313	Box frame (Right)

## Bubble vial



This robust bubble vial can be mounted on any of the accessory bases listed above in place of the Talyvel® Level Unit, to provide a simple, cost effective method of setting and checking angle and level.

It has a sensitivity of 10 seconds (0.05 mm/metre, 50  $\mu$ in/in) per division.

Tilt adjustment for setting the Level Unit to absolute horizontal is provided for all these bases. A further adjustment for eliminating roll errors, which can be significant, is also included.

## Local variation gauge



When carrying out Union Jack (Moody) measurements on larger surface tables, the operator has large triangular areas where no data is available. This gauge enables the user to make a more complete assessment. The data provided is then keyed into the 112-5105 software.

## Basic tilt plate

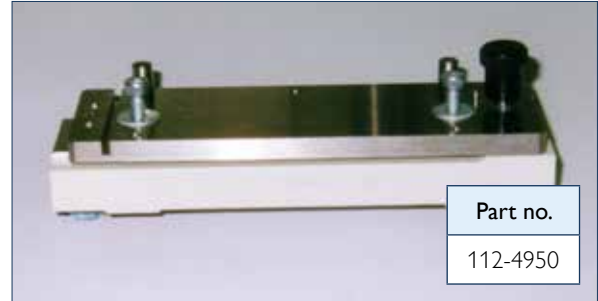

A simple base with tilt adjustment with  $\pm 3$  degrees of tilt. Enables the user to apply a mechanical offset or tilt where the standard range is inadequate but a true level is not needed.

## Small angle generator

Users can calibrate their own Talyvel® instrument using a small angle generator. It consists of a beam which is pivoted at one end on rollers; the other end can be displaced a known amount.

The beam carries a small bed with adjustable vees for checking Talyvel®'s or bubble vials. Can also be used for checking autocollimators.

Part no.
137-1918

## Micro Alignment Telescope accessories

### Digital CCD Accessory (DMAS)\* (code 137-2160-01)

Available as an accessory upgrade for existing Micro Alignment Telescopes in the field, a high resolution CCD system with software automatically senses the centre position of the dedicated CCD targets then calculates the displacement from a set datum to ensure a fast set up time with repeatable readings, as well as digitally outputting the result. This is particularly useful on large alignment projects such as aircraft jigs or large machine tools since a single operator can make measurements and adjustments along the construction or fixture while the target is displayed on the monitor.

- Clear digital output of X and Y minimises operator error
- Graphical output for reporting & storage of results
- Repeatability of measurement provided by CCD
- Rapid calculation of results for quick and easy assessment
- Ideal for automatic remote monitoring with datalogging
- Typical accuracies: 5  $\mu\text{m}$  over 3 m (decreasing with distance)

Target readings are recorded along the component and can then be output as a graph/results table or saved for further analysis. Analysis of the results can give advice on the required precise adjustment of the component under construction to bring it in line quickly.

### CCTV Camera (ViVi)\* (code 137-2161-01)

- Choice of image magnifications up to x8
- Minimises eye fatigue
- Uses notebook PC with dedicated software
- Image can be viewed in difficult/awkward locations
- Minimises parallax error

A miniature CCTV camera can be fitted to the telescope eyepiece to remotely view the target when working for example in difficult locations. The camera features fine adjustment for focus and centring. A notebook/tablet PC is included with operator software that allows the user to magnify the target image from x2 up to x8. Templates can also be selected to aid with viewing and images can be saved to archive.

Viewing the target image on the monitor allows the operator to adjust the machine tool, targets or fixtures that require setting, without having to return to the Telescope each time.

### Right Angle Eyepiece Adaptor (code 112-568)

Enables the Telescope to be viewed at right angles to the line of sight. Especially useful where space is cramped or the sighting position inconvenient.

### High Magnification Eyepiece (code 112-4940)

Eyepiece with increased magnification is available which increases the eyepiece magnification to x50.

### Laser Alignment Aid (code 112-4941)

This attaches to the telescope barrel to speed up initial setting time in finding the target.



137-2160-01 CCD Digital System Accessory with software (112-3389 when ordered as a complete telescope system including 112-850 telescope)



137-2161 CCTV accessory



112-568 Right Angle Eyepiece



Customised cases available  
These are padded and reinforced to absorb shocks. The case contains compartments to accommodate the Telescope and its accessories.

## Mounting the telescope (Micro Alignment Telescope)

### Adjusting Bracket (code 112-5817)

Provides a fine azimuth and elevation adjustment for sighting the Telescope, used with a Horizontal Base or Bore Fixture.

### Horizontal Base (code 112-5820)

Used for mounting the Adjusting Bracket onto either the Plain, Flange or Adjustable Cup. When used on flat surfaces (plain cup), two fence pins provide a sideways location.

### Plain Cup (code 112-472)

Locates the Mounting Sphere on the Horizontal Base with its centre 73.5 mm (2.9 in) from the base of the Cup.

### Flange Cup (code 112-471)

Locates the Mounting Sphere on the Horizontal Base with its centre 110 mm (4.33 in) from the base of the Cup.

### Adjustable Height Cup (code 112-849)

Similar to code 112-471, but adjustable to height 110 mm  $\pm 5$  mm (4.33 in  $\pm 0.188$  in).

### Mounting Sphere (code 112-376 or basic 112-5823)

The Mounting Sphere accepts either the Telescope or Target. Used on the Telescope it serves to provide a pivot when sighting the Telescope. The line of sight always passes through the Sphere centre.

A Collet Clamp key (code 116-27) serves any number of spheres. A shoulder ring (code 112-465) positions the pattern side of the Target at the centre of the sphere and is threaded to take the Target Illuminator (code 112-642).

### Bore Fixture (code 112-5814)

Used in conjunction with the Adjusting Bracket and Mounting Sphere to mount the Telescope in bores. The mounting diameter of 120.625-120.637 mm (4.7490-4.7495 in) is concentric with the Sphere.

### Trivets (code 137-1906, 112-5825 & 112-5824)

Used to mount the Telescope remotely from the work. Trivets provide an extremely rigid mounting up to approximately 2 metres (78 in) high. Tripods are also available (code 112-4942 and adaptor 112-4943)

### Unimount (code 137-1916)

This lightweight universal mounting system is used when using the Telescope remotely from the component to be measured. It is normally mounted on Trivet Stands to the required height and provides all the facilities for moving the Telescope through  $\pm 2.5^\circ$  elevation,  $\pm 2^\circ$  fine ( $360^\circ$  coarse) azimuth, 100 mm (3.9 in) vertical, 76 mm (3 in) horizontal and 40 mm (1.6 in) sideways. A simpler version is also available (code 112-5451)



112-5817 & 112-5820 shown with 112-5823 sphere, cup and telescope with right angle eyepiece



112-471, 112-472, 112-849



112-5814 shown with alignment telescope (inc. 112-5817 & 112-5823)



112-5823 with adaptor



137-1906 table top with 112-5823 trivets, 112-5824 rods and 112-471 flange cup



137-1916 shown on trivets/rods with alignment telescope

## Mounting the target (Micro Alignment Telescope)

### Sphere Clamp (code 112-657)

Retains the sphere onto its Mounting Cup when the Sphere is used to hold a Target.

### Target Illuminator\* (code 112-642)

This accessory provides glare free background illumination for ideal viewing of the Target pattern.

The illuminator fits the sphere, shoulder ring, adjustable target holder and spider fixture. A battery operated version is also available. (code 112-3453). When working over long distances, a high intensity target illuminator (code 137-4944) is available, incorporating a green LED light source and brightness adjustment.

### Adjustable Target Holder (code 112-837)

Normal height from base to centre of target 76 mm (3 in) and a range of vertical and horizontal adjustment of approx  $\pm 3$  mm (0.125 in). It has magnetic feet, can be located against fence pins and incorporates vertical and horizontal adjustment screws. Takes 2.25 in targets and is threaded to accept the target illuminator.

### Spider Fixture (code 137-5813)

Enables a target to be positioned in the centre of bores from 200 mm to 1 m (8-40 in). Larger diameter fittings to special request. Target centring is shown by a rotating dial indicator. The spider fixture is threaded to take the illuminator. Uses 1.5 in targets.



112-657 (shown with 112-642, sphere & cup)



112-837 (shown with target)

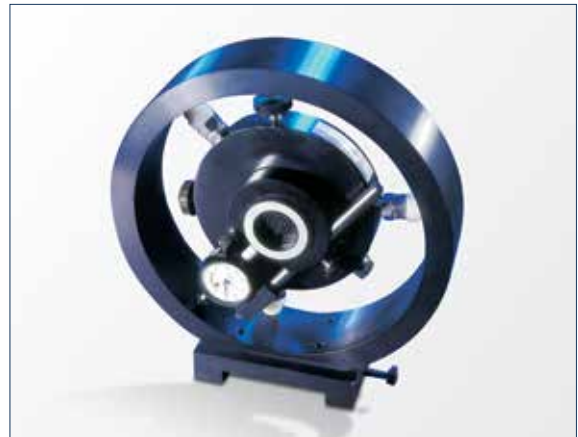

137-5813 (shown with target in a demonstration ring)

## Optical squares (Micro Alignment Telescope)

These are used to deviate the Telescope's line of sight precisely  $90^\circ$  within 1 arc second; ie  $5 \mu\text{m}$  per metre. The 4 in offset square is mounted on the barrel of the Telescope. Rotated with the Telescope, it is used to sweep out planes perpendicular to the Telescope reference line of sight.

### Optical Square (code 142-77)

This optical square enables a  $90^\circ$  line of sight to be set up vertically or horizontally from the Telescope.

The height of the sighting aperture is normally 76 mm (3 in) corresponding to the Plain Cup mounting height for the Telescope. A reduced specification version (code 142-212) is also available.

### 4 in Offset Square (code 112-1130)

Has its  $90^\circ$  line of sight 4 in (102 mm) forward of its mounting sphere and is used to sweep the full  $360^\circ$ . It has a through sighting facility, enabling the reference target to be viewed at all times.



142-77



112-1130



## Autoreflexion and autocollimation\* (Micro Alignment Telescope)

When fitted with a lamphouse, the Micro Alignment Telescope can be used for setting or checking squareness, and measuring small gradients of tilt, by autoreflexion or autocollimation.

### Telescope Lamphouse (code 112-1365)

Inserted into the Telescope to illuminate the integral cover glass target, it has a partially reflecting mirror that does not obscure the line of sight. Power supply included.

### Adjustable Mirror Target Holder (code 112-729)

For mounting a Mirror Target on the end of a rotating spindle or shaft. The two adjusting screws enable the mirror target to be tilted so that the spindle axis can be aligned with the Telescope line of sight, using Autoreflexion. Has a 95.25 mm (3.75 in) diameter locating spigot concentric with the Target pattern.



112-1365



112-729 (shown with mirror)

### Squaring-On Reflector (code 112-722)

Assists in preliminary lining up of the workpiece when the Autoreflexion image is initially outside the Telescope field of view. Two images are seen through the viewing aperture and these converge as the workpiece is brought square to the line of sight.

## Setting a vertical line of sight (Micro Alignment Telescope)

### Vertical Base (code 112-4945)

Used for setting a true vertical line of sight. Includes a bore fixture with adjusting bracket and sphere. The bore fixture adaptor contains a mirror that can be levelled with a Talyvel® differential system (not included). The mirror is set truly horizontal then the MAT is set square to it, producing the vertical reference line. Typical applications include setting refuelling rods truly vertical and setting defence platforms to gravity.

## Telescope calibration equipment (Micro Alignment Telescope)

Intended for users who wish to carry out their own calibration check on their Telescopes, including variable focus collimator (code 137-583), rotating Test Wedge (code 137-829) and Micro Alignment Telescope bench (code 137-1917).

Parallelism of the Telescope line of sight with respect to the barrel of the Telescope is checked by sighting into the Variable Focus Collimator and revolving the Telescope through 180°.



137-1917

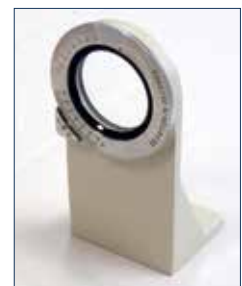

137-829

The variable focus of the collimator simulates all focal distances, enabling the straightness of the Telescope line of sight to be checked. The graduated scale target on the front of the collimator is used for checking concentricity of the Telescope line of sight to its barrel, and also linearity of the Telescope micrometers. The test wedge is used to measure the angle of parallelism.

\* Digital Micro Alignment Telescope (code 112-3389) cannot measure in this mode.

## Levelling bases and stands (Autocollimator)

### Levelling base (code K501-3341)

The levelling base provides support for the Autocollimator, enabling the unit to be levelled and to bring its axis parallel to the surface being measured. It incorporates clamps to securely hold the Autocollimator without damage.

- Spacing between front and back foot screws: 205 mm (8 in)
- Spacing between the two back foot screws: 130 mm (5 in)
- Height of Autocollimator axis when base is resting on the pads: 76 mm (3 in) without pads: 67 mm (2.5 in)
- Range of angular adjustments: approx  $\pm 3^\circ$
- Approximate weight: 3.4 kg (7.5 lbs)



Vertical Base with bracket (112-3451/112-3450) and Levelling base (K501-3341)

### Vertical Base with Adjusting Bracket (code 112-3451\* or 112-3450\*\*)

A multipurpose stand of sturdy construction for general bench use, comprising epoxy granite surface plate, and ground cast iron column and bracket. The Autocollimator clamping bracket has independent clamping and rotational adjustments, enabling the bracket to be turned without disturbing the height adjustment.

- Available for use with 25.4 mm (1 in), 38 mm (1.5 in) and 57 mm (2.25 in) diameter autocollimators.
- Surface Plate Area: 220 x 150 mm (8.7 x 5.9 in)
- Maximum Height Adjustment above Surface Plate: 200 mm (8 in)
- Flatness of Surface: 5  $\mu\text{m}$  (0.0002 in)
- Approx Weight: 7.6 kg (16.8 lbs)



Azimuth base (112-4946)

### Tripod (code 112-4942)

Adjustable tripod up to 1.4 m (other models available). Used with adaptor plate (112-4947) to hold Ultra Autocollimator.

### Adaptor Bushes (code 112-2257)

A set of two bushes to convert standard levelling bases (142-76) to 38 mm (1.5 in) diameter for use with VA900.

### Azimuth Base (code 112-4946)

To give  $\frac{1}{2}$  degree fine adjustment of azimuth elevation on Ultra and TA51.



Adjustable tripod is available as an alternative to the unimount (112-4942 & adaptor 112-4943)



Adaptor plate (112-4947) shown on tripod

\* TA60, 25.4 mm (1 in) dia. clamp.

\*\* VA900, 38 mm (1.5 in) dia. clamp.

## Straightness & flatness measurement (Autocollimator)

### Standard glass reflector 50 mm (2 inch) (code 142-24)

A reflector is an integral part of any Autocollimator system. Successful autocollimation requires a reflector of adequate flatness, reflectivity and diameter; this reflector meets all of these requirements. Steel reflectors and unmounted versions can be supplied to special order.

Also available with a double sided reflector (112-5467) or as a single sided adjustable reflector (112-5468).

- Diameter: 50 mm (2.0 in) nominal
- Faces Parallel to Within: 5 secs
- Faces Flat to Within: 0.1  $\mu\text{m}$  (3.8  $\mu\text{in}$ )
- Centre height of Mounted Reflector: 37 mm (1.5 in)
- Weight Unmounted: 130 g (9 oz)
- Mounted: 1.1 kg (2.5 lbs)

### Fixed base for 142-24

(code 112-4948 - 100 mm or 112-4949 - 200 mm)

Fixed reflector carriage used to mount reflector (142-24). Magnetic versions are also available (112-5437 - 100 mm and 112-5438 - 200 mm).

### Large glass reflector mounted 80 mm - 3 inch (code 142-26)

Offering a large reflective surface, this is normally used together with a reflector carriage and mounted reflector (142/24) for calibrating a surface plate. It enables several calibration lines to be traversed without the Autocollimator being moved, thereby saving setting up time.

### Large glass reflector with On/Off magnetic base (code 112-5591)

This large mirror is mounted securely to a machine tool carriage for straightness checks with the aid of an On/Off magnetic base. 110 mm length - longer lengths available on request.

### Adjustable base (code 112-2316 - Standard or 112-5826 - Simple)

This accessory has a 200 mm (8 in) range of adjustment and can be set to the appropriate step interval length for flatness and straightness measurement. It provides a base for the reflector (142/24) with self aligning seating pads adjustable to a graduated scale. This base can also be used for mounting a Talyvel® level unit. Fixed bases can be supplied on request.

### Side feet (code 112-1947\* or 112-5827\*\*)

For use with the Adjustable Base when measuring in two axes.



Reflector mounted on adjustable base (112-5826) with side feet (112-2316), for two axis straightness measurement



Reflectors (left - 142-24, right - 142-26)



Flat reflector with magnetic base (112-5591)

\* For use with 112-2316.

\*\* For use with 112-5826.

## Squareness & parallelism measurement (Autocollimator)

### Optical square (code 142-77)

- Aperture: 38 mm (1.5 in) 90° angle accurate to within  $\pm 1$  sec

This square comprises a mounted pentagonal prism and is used to deviate the autocollimator beam through 90°.

It may be used when checking the straightness of two surfaces which are at right angles to one another or when checking parallelism. A lower specification version is available,  $\pm 3$  sec (142-212). Adjustable base is available (112-5439).

### Cube reflector (code 142-25)

Can be used as general purpose reflector and for providing a 90° angle standard in three planes, for setting or checking perpendiculars.

- Size of Faces: 38 mm (1.5 in) square
- Reflector Faces: 3 (2 adjacent faces perpendicular to the base, 1 parallel to the base)
- Accuracy of 90° Angle:  $\pm 3$  secs
- Weight: 0.43 kg (1 lb)

Other cubes can be supplied to required specifications to special order. For example, as above but with an accuracy of 90°  $\pm 1$  sec or with four or five reflective faces.

### Adjustable table for optical square and/or Talyvel®

(code 112-5439 - optical square or 112-5592 - optical square/Talyvel®)

Allows the optical square/Talyvel® electronic level to be mounted for use in squareness and parallelism checks.



Adjustable table for optical square and Talyvel® (112-5592)

## Indexing table, polygon & angle calibration (Autocollimator)

### Polygon, 12 sided glass, nominal face angle 30° (code 142-35)

The angle between the 0° datum face and any other face is within 5 seconds of the nominal values. A calibration chart is provided with each polygon, giving the actual angles to 0.1 second of arc to an accuracy of determination of 1 second.

A simple adjustable table (112-5632) is available for tilt adjustment when carrying out indexing table measurement.

Other polygons up to 72 sides and in steel or chrome carbide can be supplied to special order.

### Angle Gauges (Set of 15) (code 142-32)

- Gauge Angle – precision square, 45°, 30°, 15°, 5°, 3°, 1°, 30 min, 20 min, 5 min, 3 min, 1 min, 30 sec, 12 sec, 6 sec
- Accuracy of Angle:  $\pm 2$  seconds

These gauges can be wrung together additively or subtractively to form most angles from 0° to 90° as a comparison standard. The faces themselves can be used as a reflector.



Set of angle gauges (142-32)



12 sided polygon (142-35)

## Test equipment (Autocollimator)

### Fixed Test Wedge (code 137-1940)

The fixed wedge can be used to quickly check the accuracy of any Autocollimator. It introduces a fixed angle of deviation nominally of 60 seconds by rotating the wedge from minimum to maximum deviation and comparing this with the readings on the Autocollimator. A UKAS certificate is optionally available.

- Centre Height: 75mm (3 in)
- Weight: 1 kg (2.25 lb)
- Working Diameter: 50 mm (2 in)

### Digital Angle Generator (Details available on request)

Autocollimators require periodic calibration to verify their capability for precise measurement. Users can calibrate their own Autocollimators using a Small Angle Generator. This device is also suitable for testing angle gauges, electronic levels, level vials used in block levels etc. A high precision version is also available.

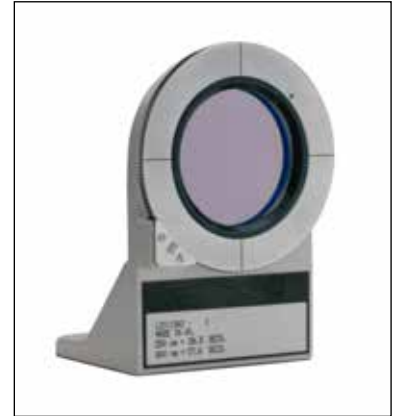

Fixed test wedge (137-1940)

## Miscellaneous accessories (Autocollimator)

### CCTV System for use with visual autocollimators (code 137-1991)

A miniature CCTV camera can be fitted to the eyepiece of the visual autocollimators when working in awkward locations or simply to reduce eye fatigue. By viewing the image on the laptop screen, the image can be magnified and a number of operators can view the image if required.

### Remote keypad (code 265-1277)

Suitable for use with Ultra Autocollimators to trigger measurements remotely.



CCTV (ViVi) system shown on VA900 autocollimator and base

## The Metrology Experts

Established in 1886, Taylor Hobson is the world leader in surface and form metrology and developed the first roundness and surface finish measuring instruments.

[www.taylor-hobson.com](http://www.taylor-hobson.com)

## Sales department

Email: [taylor-hobson.sales@ametek.com](mailto:taylor-hobson.sales@ametek.com)

Tel: +44 (0) 116 276 3771

- **Design engineering** – special purpose, dedicated metrology systems for demanding applications.
- **Precision manufacturing** – contract machining services for high precision applications and industries.

## Centre of Excellence department

Email: [taylor-hobson.cofe@ametek.com](mailto:taylor-hobson.cofe@ametek.com)

Tel: +44 (0) 116 276 3779

- **Inspection services** – measurement of your production parts by skilled technicians using industry leading instruments in accord with ISO standards.
- **Metrology training** – practical, hands-on training courses for roundness and surface finish conducted by experienced metrologists.
- **Operator training** – on-site instruction will lead to greater proficiency and higher productivity.
- **UKAS calibration and testing** – certification for artifacts or instruments in our laboratory or at customer's site.

## Service department

Email: [taylor-hobson.service@ametek.com](mailto:taylor-hobson.service@ametek.com)

Tel: +44 (0) 116 246 2900

- **Preventative maintenance** – protect your metrology investment with an AMECare support agreement.



© Taylor Hobson Ltd. 2019



### Taylor Hobson UK

(Global Headquarters)

PO Box 36, 2 New Star Road  
Leicester,  
LE4 9JQ,  
England

Tel: +44 (0)116 276 3771  
[taylor-hobson.sales@ametek.com](mailto:taylor-hobson.sales@ametek.com)



### Taylor Hobson France

Rond Point de l'Epine Champs  
Batiment D, 78990 Elancourt, France  
Tel: +33 130 68 89 30  
[taylor-hobson.france@ametek.com](mailto:taylor-hobson.france@ametek.com)



### Taylor Hobson Germany

Rudolf-Diesel-Straße 16,  
D-64331 Weiterstadt, Germany  
Tel: +49 6150 543 0  
[taylor-hobson.germany@ametek.com](mailto:taylor-hobson.germany@ametek.com)



### Taylor Hobson Italy

Via Della Liberazione 24, 20068, Peschiera  
Borromeo, Zeloфорamagno, Milan, Italy  
Tel: +39 02 946 93401  
[taylor-hobson.italy@ametek.com](mailto:taylor-hobson.italy@ametek.com)



### Taylor Hobson India

Divyasree NR Enclave, 4th Floor, Block A,  
Plot No. 1, EPIP Industrial Area, Whitefield,  
Bengaluru - 560066, India  
Tel: +91 80 6782 3346  
[taylor-hobson.india@ametek.com](mailto:taylor-hobson.india@ametek.com)



### Taylor Hobson China

[taylor-hobson-china.sales@ametek.com](mailto:taylor-hobson-china.sales@ametek.com)

#### Shanghai Office

Part A1, A4, 2nd Floor, Building No. 1, No. 526  
Fute 3rd Road East, Pilot Free Trade Zone,  
Shanghai, 200131, China  
Tel: +86 21 5868 5111-110

#### Beijing Office

Western Section, 2nd Floor, Jing Dong Fang  
Building (B10), No. 10, Jiu Xian Qiao Road,  
Chaoyang District, Beijing, 100015, China  
Tel: +86 10 8526 2111

#### Chengdu Office

No. 9-10, 10th floor, 9/F, High-tech Incubation  
Park, No. 160, Jinyue West Road, Chengdu  
610041, China  
Tel: +86 28 8675 8111

#### Guangzhou Office

Room 810 Dongbao Plaza, No.767 East  
Dongfeng Road, Guangzhou, 510600, China  
Tel: +86 20 8363 4768



### Taylor Hobson Japan

3F Shiba NBF Tower; 1-1-30, Shiba Daimon  
Minato-ku, Tokyo 105-0012, Japan  
Tel: +81 34400 2400  
[taylor-hobson.japan@ametek.com](mailto:taylor-hobson.japan@ametek.com)



### Taylor Hobson Korea

#309, 3rd FL, Gyeonggi R&DB Center; 105,  
Gwanggyo-ro, Yeongtong-gu, Suwon-si,  
Gyeonggi-do, Korea, 16229  
Tel: +82 31 888 5255  
[taylor-hobson.korea@ametek.com](mailto:taylor-hobson.korea@ametek.com)



### Taylor Hobson Singapore

AMETEK Singapore, 10 Ang Mo Kio Street 65,  
No. 05-12 Techpoint, Singapore 569059  
Tel: +65 6484 2388 Ext 120  
[taylor-hobson.singapore@ametek.com](mailto:taylor-hobson.singapore@ametek.com)



### Taylor Hobson Thailand

89/45, Moo 15, Enterprise Park, Bangna-Trad  
Road, Tambol Bangkaew, Amphur Bangplee,  
Samutprakarn Province 10540, Thailand  
Tel: +66 2 0127500 Ext 505  
[taylor-hobson.thailand@ametek.com](mailto:taylor-hobson.thailand@ametek.com)



### Taylor Hobson Taiwan

10F-5, No.120, Sec. 2, Gongdao Wu Rd.,  
Hsinchu City 30072, Taiwan  
Tel: +886 3 575 0099 Ext 301  
[taylor-hobson.taiwan@ametek.com](mailto:taylor-hobson.taiwan@ametek.com)



### Taylor Hobson Mexico

Acceso III No. 16 Nave 3 Parque Ind. Benito  
Juarez Queretaro, Qro. Mexico C.P. 76120  
Tel: +52 442 426 4480  
[taylor-hobson.mexico@ametek.com](mailto:taylor-hobson.mexico@ametek.com)



### Taylor Hobson USA

27755 Diehl Road, Suite 300, Warrenville,  
IL 60555, USA  
Tel: +1 630 621 3099  
[taylor-hobson.usa@ametek.com](mailto:taylor-hobson.usa@ametek.com)



1100 Cassatt Road, Berwyn, PA 19312, USA  
Email: [info.corp@ametek.com](mailto:info.corp@ametek.com)  
Web: [www.ametek.com](http://www.ametek.com)