

Distributed Convolutional-Coded Differential Space-Time Block Coding for Cooperative Communications

Soon Xin Ng, Yang Wang and Lajos Hanzo

School of Electronics and Computer Science, University of Southampton, SO17 1BJ, United Kingdom.

Email: {sxn,yw704,lh}@ecs.soton.ac.uk

Abstract—A low complexity distributed coding scheme is proposed for communications over Rayleigh fading channels. Convolutional Coding (CC) assisted Differential Phase-Shift Keying (DPSK) modulation is employed at the source node for conveying the source signals to two relay nodes as well as to the destination node during the first transmission period. Iterative detection exchanging extrinsic information between the DPSK demapper and CC decoder is carried out at each relay node in order to recover the source signals. Then, the CC-encoded bits are re-encoded by the two relays to generate Differential Space-Time Block Coding (DSTBC) symbols for transmission to the destination node during the second transmission period. At the destination node, iterative decoding exchanging extrinsic information is invoked between the DPSK demapper and the concatenated CC-DSTBC decoder, where the latter is viewed as a single amalgamated decoder. The relay and destination nodes do not have to estimate the channel's fading coefficients due to the employment of DPSK and DSTBC schemes. Our design requires only two decoding iterations between the DPSK and CC decoders at each relay in order to further reduce the complexity of the relay nodes. Our distributed coding scheme assisted by two low-complexity relay nodes outperforms the non-cooperative benchmarker scheme by about 8 dBs, when aiming for a bit error ratio of 10^{-5} .

Index Terms—Cooperative Diversity, Differential Space-Time Block Code, Differential Modulation, distributed coding, iterative detection.

I. INTRODUCTION

Space time coding schemes such as Space-Time Trellis Coding (STTC) [1] and Space-Time Block Coding (STBC) [2], [3], which employ multiple transmitters and receivers, are capable of providing high data rates and substantial diversity gains due to the high capacity potential of the corresponding Multiple-Input Multiple-Output (MIMO) channels [4], [5]. However, it is impractical to implement multiple antennas at each mobile unit. Cooperative communication among users is a practical solution to this problem, where single-antenna aided mobile units can form a virtual MIMO system for achieving diversity gains through the relay channels. Although the capacity of relay-aided channels was studied as early as the 1970s [6], practical cooperative diversity techniques were only proposed and investigated in recent years [7]–[10].

The most popular collaborative protocols used between the source, relay and destination nodes are Decode-And-Forward (DAF), Demodulate-And-Forward (DeAF), Compress-And-Forward (CAF) as well as Amplify-And-Forward (AAF). Distributed coding [11] constitutes another attractive cooperative diversity technique, where joint signal design and coding are invoked at the source and relay nodes. Recently, various distributed STTC [12] and distributed STBC [13] schemes were also proposed. However, strong channel codes are needed in order to protect the source-to-relay links [14], especially when the DAF protocol is employed at the relay nodes which would inflict error propagation in the Relay-Destination link in the presence of decision errors. More specifically, the transmit power required at the source node may be excessive in order to guarantee reliable decoding at the relay nodes, if the distributed STTC and

STBC schemes are not aided by an additional outer channel code. An adaptive distributed STBC based on the AAF protocol was proposed in [15] to avoid the above-mentioned error propagation problem of the DAF-based schemes. However, the AAF-based cooperative scheme is vulnerable to the noise enhancement inflicted by the relay nodes.

The above-mentioned cooperative schemes require accurate Channel State Information (CSI) at each receiving node in order to detect the transmitted signals. However, the estimation of the CSI at each node would induce a high complexity, especially when the number of cooperative nodes is high. On the other hand, differential modulation schemes, such as Differential Phase-Shift Keying (DPSK) [16], do not require the knowledge of the CSI at the receiver for signal detection. Hence, various differential modulated schemes have been proposed in the literature [17], [18]. More explicitly, Differential STBC (DSTBC) schemes [17] have been modified for employment in cooperative networks [19], [20]. However, outer channel codes have not been utilised in these DSTBC schemes. Hence their performance is either too idealistic or too far away from the virtual MIMO channel's capacity.

In this contribution, a simple Convolutional Code (CC) [21] and a classical DPSK modulation are employed at the source node. Two relay nodes will be used to form a distributed DSTBC system. Iterative detection between the CC decoder and DPSK demapper is invoked at each relay node for reliably detecting the source signals. At the destination node, iterative detection exchanging extrinsic information between the DPSK demapper and the concatenated CC-DSTBC decoder is performed for recovering the source signals. Our proposed distributed and differentially modulated scheme is designed using EXtrinsic Information Transfer (EXIT) charts [22], [23] and its performance is verified by Monte-Carlo simulations.

The paper is organised as follows. The system model is described in Section II, while the system design and analysis is outlined in Section III. Simulation results are discussed in Section IV and our conclusions are offered in Section V.

II. SYSTEM MODEL

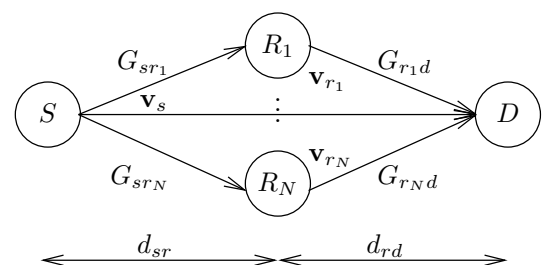

Fig. 1. Schematic of a two-hop relay-aided system, where d_{ab} is the geographical distance between node a and node b .

The financial support of the EPSRC UK and that of the European Union under the auspices of the Optimix project is gratefully acknowledged.

Fig. 1 shows the schematic of a two-hop relay-aided system, where the source node (s) transmits a frame of coded DPSK symbols

\mathbf{v}_s to N number of relay nodes (r) as well as to the destination node (d) during the first transmission period. Each relay node first decodes and then re-encodes the information. The N cooperating relay nodes will collectively form a virtual DSTBC frame of $\mathbf{V}_r = [\mathbf{v}_{r_1}, \mathbf{v}_{r_2}, \dots, \mathbf{v}_{r_N}]^T$ for transmission to the destination node during the second transmission period. The communication links seen in Fig. 1 are subject to both free-space propagation path loss as well as to a Rayleigh fading channel. We consider $N = 2$ relay nodes in this paper. Each source, relay and destination node is equipped with a single antenna.

Let d_{ab} denote the geometrical distance between nodes a and b . The geometrical-gain experienced by the link between the source node and the i th relay node with respect to the source-to-destination link as a benefit of its reduced distance and path loss can be computed as [10], [14]:

$$G_{sr_i} = \left(\frac{d_{sd}}{d_{sr_i}} \right)^2. \quad (1)$$

Similarly, the geometrical-gain of the i th relay-to-destination link with respect to the source-to-destination link can be formulated as:

$$G_{r_i d} = \left(\frac{d_{sd}}{d_{r_i d}} \right)^2. \quad (2)$$

We have $G_{sd} = 1$ because the geometrical-gain of the source-to-destination link with respect to itself is unity.

The k th received signal at the i th relay node during the first transmission period, where N_s symbols are transmitted from the source node, can be written as:

$$y_{sr_i, k} = \sqrt{G_{sr_i}} h_{sr_i, k} v_{s, k} + n_{r_i, k}, \quad (3)$$

where $k \in \{1, \dots, N_s\}$, $i \in \{1, \dots, N\}$ and $h_{sr_i, k}$ is the Rayleigh fading coefficient between the source node and the i th relay node at instant k , while $n_{r_i, k}$ is the AWGN having a variance of $N_0/2$ per dimension. The k th received signal at the destination node during the first transmission period can be written as:

$$y_{sd, k} = \sqrt{G_{sd}} h_{sd, k} v_{s, k} + n_{d, k}, \quad (4)$$

where $k \in \{1, \dots, N_s\}$, $G_{sd} = 1$ and $h_{sd, k}$ is the Rayleigh fading coefficient between the source node and the destination node at instant k , while $n_{d, k}$ is the AWGN having a variance of $N_0/2$ per dimension.

The j th symbol received at the destination node during the second transmission period, where N_r symbols are transmitted from each relay node, is given by:

$$y_{rd, j} = \sum_{i=1}^N \sqrt{G_{r_i d}} h_{r_i d, j} v_{r_i, j} + n_{d, j}, \quad (5)$$

where $j \in \{1, \dots, N_r\}$ and $h_{r_i d, j}$ denotes the Rayleigh fading coefficient between the i th relay node and the destination node at instant j , while $n_{d, j}$ is the AWGN having a variance of $N_0/2$ per dimension. The power transmitted by each relay node is normalised to one, i.e. $\sum_{i=1}^N |v_{r_i, j}|^2 = 1$.

If $v_{a, j}$ is the j th symbol transmitted from node a equipped with a single transmit antenna, the average received Signal to Noise power Ratio (SNR) experienced at each receive antenna at node b is given by:

$$\text{SNR}_r = \frac{\text{E}\{G_{ab}\}\text{E}\{|h_{ab, j}|^2\}\text{E}\{|v_{a, j}|^2\}}{N_0} = \frac{G_{ab}}{N_0}, \quad (6)$$

where $\text{E}\{|h_{ab, j}|^2\} = 1$ and $\text{E}\{|v_{a, j}|^2\} = 1$. We define furthermore the ratio of the power transmitted from node a to the noise power encountered at the receiver of node b as:

$$\text{SNR}_t = \frac{\text{E}\{|v_{a, j}|^2\}}{N_0} = \frac{1}{N_0}. \quad (7)$$

In other words, we have:

$$\begin{aligned} \text{SNR}_r &= \text{SNR}_t G_{ab}, \\ \gamma_r &= \gamma_t + 10 \log_{10}(G_{ab}) \text{ [dB]}, \end{aligned} \quad (8)$$

where $\gamma_r = 10 \log_{10}(\text{SNR}_r)$ and $\gamma_t = 10 \log_{10}(\text{SNR}_t)$.

III. SYSTEM DESIGN AND ANALYSIS

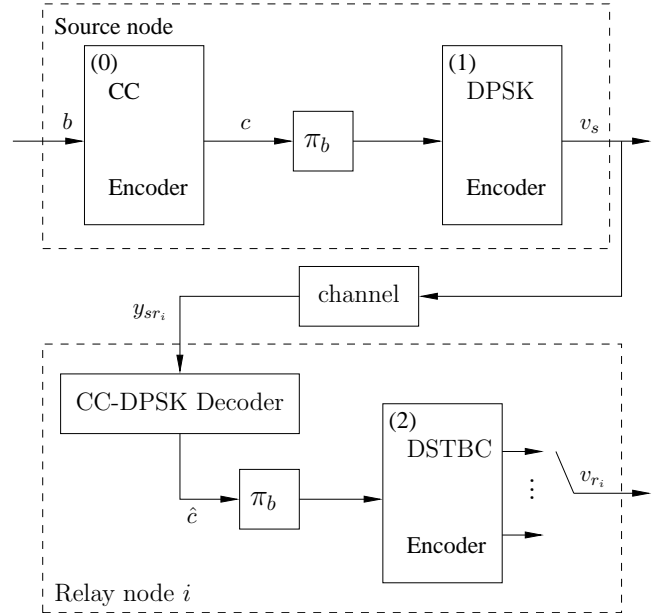

Fig. 2. The schematic of the proposed CC-assisted DPSK-modulated distributed DSTBC system.

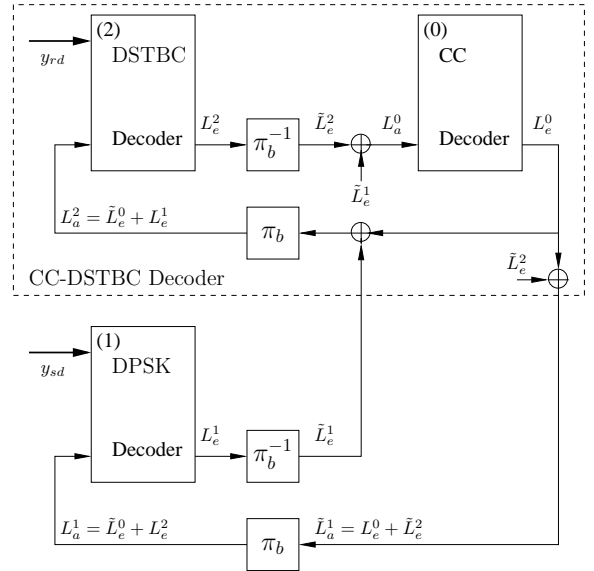

Fig. 3. The schematic of the iterative decoder of the proposed scheme at the destination node.

The schematic of the proposed CC-assisted DPSK-modulated distributed DSTBC system is shown in Fig. 2. In this paper we considered a rate $R_{cc} = 0.5$ memory-four CC [21] having a generator polynomial of [35 23] expressed in octal format, as well as a 16PSK-based DPSK scheme at the source node. A twin-antenna assisted 16PSK-based DSTBC scheme [17] is formed by the two relay nodes.

A two-component CC-DPSK iterative decoder is constructed at each relay node, while a three-component CC-DPSK-DSTBC iterative decoder of Fig. 3 is invoked at the destination node.

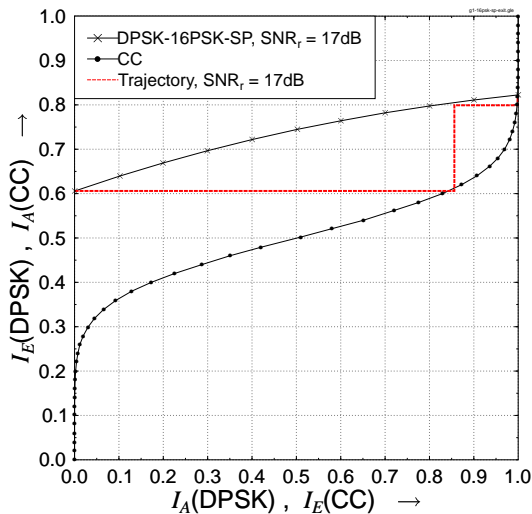

Fig. 4. The EXIT curves of the DPSK-16PSK-SP and CC schemes together with a decoding trajectory.

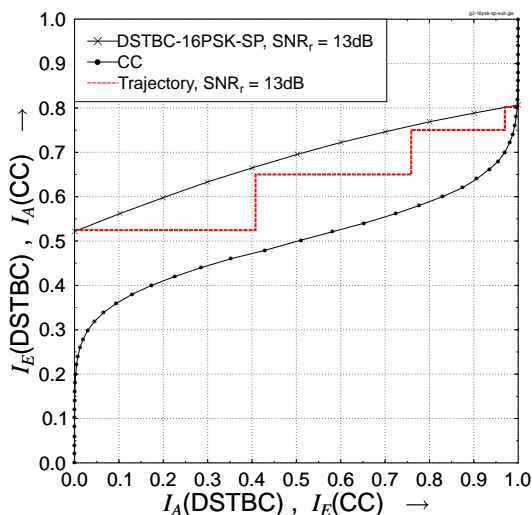

Fig. 5. The EXIT curves of the DSTBC-16PSK-SP and CC schemes together with a decoding trajectory.

The EXIT charts of the CC-DPSK and CC-STBC decoders are depicted by Fig. 4 and Fig. 5, respectively. As observed from Fig. 4, when the number of decoding iterations is fixed to two, we can use a simple CC to assist the Set-Partitioning (SP) based DPSK-16PSK scheme. However, the open EXIT-tunnel area between the EXIT curves of the DPSK-SP demapper and the CC decoder is relatively large. Note that the open EXIT chart tunnel area is proportional to the distance from the channel capacity [22], [23]. Hence, the CC-DPSK scheme is not operating near the channel capacity, when the number of decoding iterations is fixed to two. If the decoding complexity at the relay nodes is not stringently limited, we can employ more advanced outer channel codes to reduce the tunnel area between the EXIT curves at the cost of a higher number of decoding iterations. However, this will impose a higher decoding complexity at the relay nodes. On the other hand, the CC-DSTBC decoder requires a higher number of decoding iterations for attaining a decoding convergence at

$I_E(\text{CC}) = 1.0$, as shown in Fig. 5. This is acceptable, again, provided that the destination node can tolerate a higher decoding complexity.

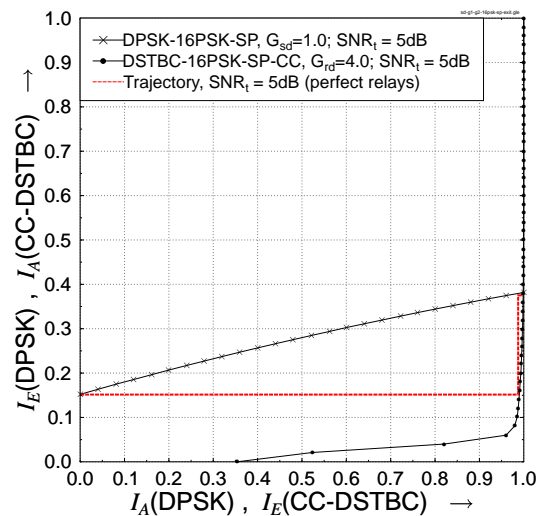

Fig. 6. The EXIT curves of the DPSK-16PSK-SP and CC-DSTBC-16PSK-SP schemes together with a decoding trajectory.

The EXIT curves of the proposed three-component decoder at the destination node are shown in Fig. 6, when assuming perfect decoding at the relays. The relays are assumed to be located at the mid-point between the source and destination nodes, i.e. $G_{sr} = G_{rd} = 4$.

Let N_i denote the number of information bits transmitted within a duration of $(N_s + N_r)$ symbol periods, where N_s is the number of DPSK symbols per frame emanating from the source node and N_r is the number of DSTBC symbols per frame transmitted from the relay nodes. We have $N_s = N_r$ in our case. We do not employ trellis termination for the CC encoder and hence we have $N_i = \log_2(16) R_{cc} N_s = 2 N_s$, for the 16PSK-based DPSK/DSTBC scheme. The overall throughput of this two-hop cooperative scheme can then be computed as:

$$\eta = \frac{N_i}{N_s + N_r} = 1 \text{ [bps]}. \quad (9)$$

Without loss of generality, we assume that both relay nodes are located on the direct line-of-sight path between the source and destination nodes, hence:

$$d_{sd} = d_{sr} + d_{rd}. \quad (10)$$

Then, from Eqs. (1), (2) and (10), we have:

$$1 = \frac{1}{\sqrt{G_{sr}}} + \frac{1}{\sqrt{G_{rd}}}, \quad (11)$$

$$G_{rd} = \left(\frac{1}{1 - 1/\sqrt{G_{sr}}} \right)^2. \quad (12)$$

If we assume that the transmit power at the source node equals the sum of the transmitted power of all $N = 2$ relay nodes, i.e. the SNR_t at the source node ($\gamma_{t,sr}$) equals the total SNR_t of the relay nodes ($\gamma_{t,rd}$), then we have:

$$\gamma_{t,rd} = \gamma_{t,sr}, \quad (13)$$

$$\gamma_{r,rd} - 10 \log_{10}(G_{rd}) = \gamma_{r,sr} - 10 \log_{10}(G_{sr}), \quad (14)$$

$$\frac{G_{rd}}{G_{sr}} = 10^{\gamma_{d-r}/10}, \quad (15)$$

where $\gamma_{d-r} = \gamma_{r,rd} - \gamma_{r,sr}$ is the difference between the receiver's average SNR at the destination node during the second transmission period and the receiver's average SNR at each relay node during

the first transmission period. Based on the above equations, we can compute the values of G_{sr} and G_{rd} for a given γ_{d-r} as follows:

$$G_{sr} = \left(1 + 10^{-\gamma_{d-r}/20}\right)^2, \quad (16)$$

$$G_{rd} = \left(1 + 10^{\gamma_{d-r}/20}\right)^2. \quad (17)$$

IV. RESULTS AND DISCUSSIONS

Let us now compare our EXIT chart predictions to our Monte-Carlo simulation results. We consider the following eight schemes in our simulation study:

- 1) CC-DPSK-GRAY: Gray-labelled 16PSK-assisted non-cooperative CC-DPSK scheme;
- 2) CC-DPSK-SP: SP-labelled 16PSK-assisted non-cooperative CC-DPSK scheme;
- 3) CC-DSTBC-GRAY: Gray-labelled 16PSK-assisted non-cooperative CC-DSTBC scheme;
- 4) CC-DSTBC-SP: SP-labelled 16PSK-assisted non-cooperative CC-DSTBC scheme;
- 5) CC-DPSK-DSTBC: SP-labelled distributed scheme without the source-to-destination link using relays at the mid-way;
- 6) CC-DPSK-DSTBC-O: SP-labelled distributed scheme without the source-to-destination link using relays at optimum position;
- 7) CC-DPSK-DSTBC-SD: SP-labelled distributed scheme with the source-to-destination link using relays at the mid-way;
- 8) CC-DPSK-DSTBC-SD-O: SP-labelled distributed scheme with the source-to-destination link using relays at optimum position.

The CC-DPSK-DSTBC and CC-DPSK-DSTBC-O schemes employ only the CC-DSTBC decoder at the destination node, which is shown as the top section of Fig. 3. The frame length is fixed to $N_s = N_r = 5000$ DPSK/DSTBC symbols for communications over Rayleigh fading channels having a normalised Doppler frequency of 0.01.

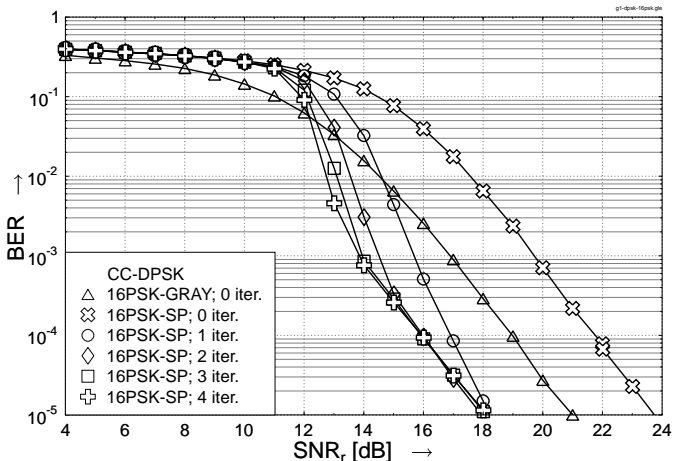

Fig. 7. BER versus SNR_r performance of the CC-DPSK-16PSK-SP and CC-DPSK-16PSK-GRAY schemes when communicating over correlated Rayleigh fading channel having a normalised Doppler frequency of 0.01 using a frame length of $N_s = 5000$ 16QAM symbols.

As predicted by the EXIT charts of Fig. 4, the Bit Error Ratio (BER) of the CC-DPSK-SP scheme has converged to a low value of 3×10^{-5} at $\text{SNR}_r = 17$ dB, as seen in Fig. 7. The high BER floor is due to the tail of the CC EXIT curve at the top-right corner of Fig. 4, where $I_E(\text{CC})$ is very close to one, but it is only equal to one at a high SNR, when we have $I_A(\text{CC}) > 0.9$. As seen from Fig. 7, the CC-DPSK-SP scheme only needs two decoding iterations

in order to achieve a BER of 10^{-5} at $\text{SNR}_r = 18$ dB, which is about 3 dB lower than that required by the CC-DPSK-GRAY scheme.

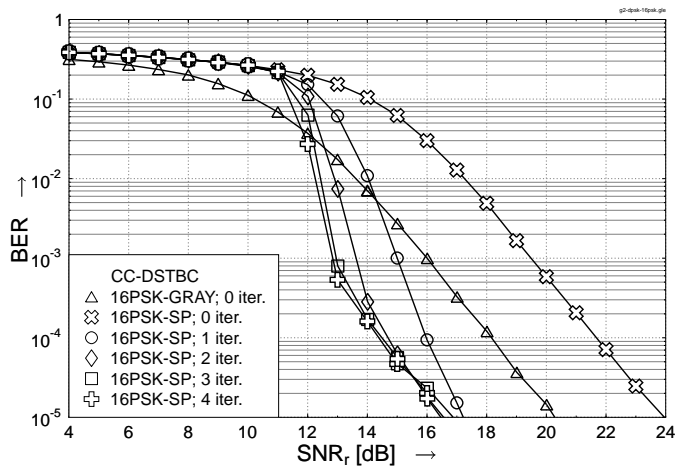

Fig. 8. BER versus SNR_r performance of the CC-DSTBC-16PSK-SP and CC-DSTBC-16PSK-GRAY schemes when communicating over correlated Rayleigh fading channel having a normalised Doppler frequency of 0.01 using a frame length of $N_s = 5000$ 16QAM symbols.

Similarly, as predicted by the EXIT charts of Fig. 5, the BER curve of the CC-DSTBC-SP scheme seen in Fig. 8 starts to form a BER floor at $\text{SNR}_r = 13$ dB. The CC-DSTBC-SP arrangement outperforms its CC-DSTBC-GRAY counterpart by about 3.2 dB at a BER of 10^{-5} after the third decoding iteration.

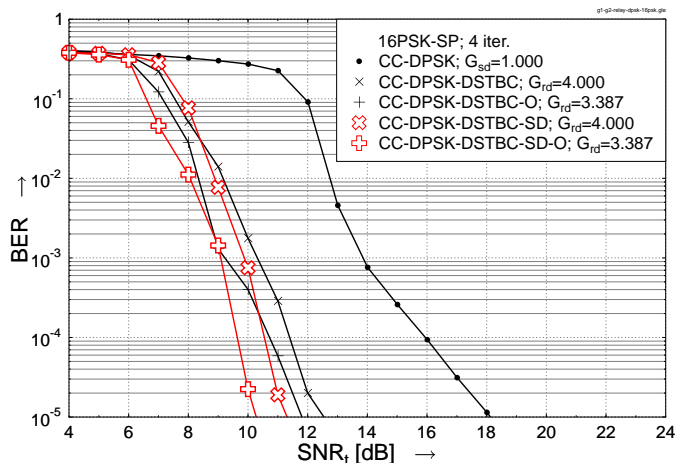

Fig. 9. BER versus SNR_r performance of the 16PSK-SP aided CC-DPSK, CC-DPSK-DSTBC, CC-DPSK-DSTBC-O, CC-DPSK-DSTBC-SD and CC-DPSK-DSTBC-SD-O schemes when communicating over correlated Rayleigh fading channel having a normalised Doppler frequency of 0.01 using a frame length of $N_s = 5000$ 16QAM symbols.

Fig. 9 shows the BER performance of four distributed CC-DPSK-DSTBC schemes in comparison to the non-cooperative CC-DPSK scheme, when SP-based 16PSK is used. At a BER of 10^{-5} , we have $\gamma_{r, sr} = 18$ dB for the CC-DPSK-SP scheme in Fig. 7 as well as $\gamma_{r, rd} = 16.5$ dB for the CC-DSTBC-SP scheme in Fig. 8. Based on these received SNR values, we can compute the optimum geometrical gains¹ using Eqs. (16) and (17) for the CC-DPSK-DSTBC-O and CC-DPSK-DSTBC-SD-O schemes. As we can see from Fig. 9, none of the distributed CC-DPSK-DSTBC arrangements can attain a low BER at the predicted value of $\text{SNR}_t = 5$ dB, despite the fact that this

¹The optimum relay locations can be calculated based on the optimum geometrical gains using Eqs. (1) and (2).

was predicted by the perfect-relay based EXIT charts in Fig. 6. This is due to the error propagation encountered at the relay nodes, when the received SNR is insufficiently high. Naturally, the performance of the various cooperative communications systems proposed in the literature assuming perfect decoding at the relay nodes are too optimistic, especially when no outer channel code is used to assist the system. Nonetheless, the proposed CC-DPSK-DSTBC-SD-O scheme still outperforms the non-cooperative CC-DPSK schemes by about 8dBs at a BER of 10^{-5} , despite the potential error propagation effects imposed by from the relay nodes.

V. CONCLUSION

A practical end-to-end distributed coding scheme was proposed and studied, which takes into consideration both the various practical limitations imposed by the communication links and the relay node complexity. Differential modulation was considered for reducing the complexity of the relay and destination nodes. Two decoding iterations were invoked at each relay node for further reducing the associated complexity. The optimum relay location was calculated based on our EXIT chart analysis and BER performance. Finally, a novel three-component decoder was employed at the destination node for detecting the source signals. It was shown in Fig. 9 that our practically motivated low-complexity distributed coding scheme is capable of attaining an SNR gain of about 8 dBs, when compared to a non-cooperative scheme.

REFERENCES

- [1] V. Tarokh, N. Seshadri, and A. R. Calderbank, "Space-time codes for high data rate wireless communication: Performance criterion and code construction," *IEEE Transactions on Information Theory*, vol. 44, pp. 744–765, March 1998.
- [2] S. M. Alamouti, "A simple transmit diversity technique for wireless communications," *IEEE Journal on Selected Areas in Communications*, vol. 16, pp. 1451–1458, October 1998.
- [3] V. Tarokh, H. Jafarkhani, and A. R. Calderbank, "Space-time block coding for wireless communications: Performance results," *IEEE Journal on Selected Areas in Communications*, vol. 17, pp. 451–460, March 1999.
- [4] G. Foschini Jr. and M. Gans, "On limits of wireless communication in a fading environment when using multiple antennas," *Wireless Personal Communications*, vol. 6, pp. 311–335, March 1998.
- [5] E. Telatar, "Capacity of multi-antenna Gaussian channels," *European Transactions on Telecommunication*, vol. 10, pp. 585–595, Nov–Dec 1999.
- [6] T. M. Cover and A. El Gamal, "Capacity theorem for the relay channel," *IEEE Transactions on Information Theory*, vol. 25, pp. 572 – 584, September 1979.
- [7] A. Sendonaris, E. Erkip and B. Aazhang, "User cooperation diversity part I: System description," *IEEE Transactions on Communications*, vol. 51(11), pp. 1927–1938, 2003.
- [8] N. Laneman, D. N. C. Tse and G. W. Wornell, "Cooperative diversity in wireless networks: efficient protocols and outage behavior," *IEEE Trans. on Information Theory*, vol. 50, no. 12, pp. 3062–3080, 2004.
- [9] E. Zimmermann, P. Herhold and G. Fettweis, "On the performance of cooperative relaying protocols in wireless networks," *European Transactions on Telecommunications*, vol. 16, no. 1, pp. 5–16, 2005.
- [10] H. Ochiai, P. Mitran and V. Tarokh, "Design and analysis of collaborative diversity protocols for wireless sensor networks," in *Proceedings of IEEE VTC Fall*, (Los Angeles, USA), pp. 4645 – 4649, 26-29 September 2004.
- [11] Y. Li, "Distributed coding for cooperative wireless networks: An overview and recent advances," *IEEE Communications Magazine*, vol. 47, pp. 71–77, August 2009.
- [12] J. Yuan, Z. Chen, Y. Li and L. Chu, "Distributed space-time trellis codes for a cooperative system," *IEEE Transactions on Wireless Communications*, vol. 8, pp. 4897 – 4905, October 2009.
- [13] S. Yiu, R. Schober and L. Lampe, "Distributed space-time block coding," *IEEE Transactions on Communications*, vol. 54, pp. 1195 – 1206, July 2006.
- [14] S. X. Ng, Y. Li and L. Hanzo, "Distributed turbo trellis coded modulation for cooperative communications," in *Proceedings of International Conference on Communications (ICC)*, (Dresden, Germany), pp. 1–5, 14-18 June 2009.
- [15] J. Abouei, H. Bagheri and A. K. Khandani, "An efficient adaptive distributed space-time coding scheme for cooperative relaying," *IEEE Transactions on Wireless Communications*, vol. 8, pp. 4957 – 4962, October 2009.
- [16] J. G. Proakis, *Digital Communications*. New York: Mc-Graw Hill International Editions, 3rd ed., 1995.
- [17] V. Tarokh and H. Jafarkhani, "A differential detection scheme for transmit diversity," *IEEE Journal on Selected Areas in Communications*, vol. 18, no. 7, pp. 1169 – 1174, 2000.
- [18] L. Hanzo, S. X. Ng, W. Webb and T. Keller, *Quadrature Amplitude Modulation: From Basics to Adaptive Trellis-Coded, Turbo-Equalised and Space-Time Coded OFDM, CDMA and MC-CDMA Systems, Second Edition*. New York, USA : John Wiley and Sons, 2004.
- [19] Q. Zhao and H. Li, "Differential modulation for cooperative wireless systems," *IEEE Transactions on Signal Processing*, vol. 55, pp. 2273–2283, May 2007.
- [20] Z. Fang; L. Li; X. Bao and Z. Wang, "Generalized differential modulation for amplify-and-forward wireless relay networks," *IEEE Transactions on Vehicular Technology*, vol. 58, pp. 3058 – 3062, July 2009.
- [21] S. Lin and D. Costello Jr., *Error Control Coding: Fundamentals and Applications*. Englewood Cliffs, NJ, USA: Prentice-Hall, October 1982. ISBN: 013283796X.
- [22] S. ten Brink, "Convergence behaviour of iteratively decoded parallel concatenated codes," *IEEE Transactions on Communications*, vol. 49, pp. 1727–1737, October 2001.
- [23] J. Kliever, S. X. Ng, and L. Hanzo, "Efficient computation of EXIT functions for non-binary iterative decoding," *IEEE Transactions on Communications*, vol. 54, pp. 2133–2136, December 2006.